



Steel Roofing and Walling Manual



GRS
GLOBAL ROOFING SOLUTIONS
Reg no 2002/032026/07

CONTENTS

1. Introduction	2	6. Rib Cap Bent Continuous	
2. Sheet Selection	3	Sheeting	23
2.1 Product Range Data	4	7. Cranking and Bullnosing Sheets	23
2.2 Wind Forces on Roofs	5	8. Curved Sheeting	24
2.3 Codes and Performance Tests	5	9. Sprung Curved Sheeting	24
2.4 Maintenance Procedures	5	10. Translucent Sheeting	24
2.5 Run-off Water- Compatibility	5	11. Insulation	26
3. General Care and Handling	5	12. Rainwater Run-off	28
3.1 Care and Storage prior to Installation	5	13. Gutter Capacity	28
3.2 Handling on Site	5	14. Downpipe Capacity	28
3.3 Walking on Roof Sheeting	6	15. Hail guards	29
3.4 Cutting Sheets on Site	6	16. Condensation	29
3.5 Cleaning Up	6	17. Sealants	30
3.6 55% Aluminium Zinc Alloy Coated material	6		
4. Installation Procedures	6		
4.1 General Procedure	6		
4.2 Pierced Fix Fastening	7		
4.2.1 Side Lapping	7		
4.2.2 Crest Fastening	7		
4.2.3 Valley Fastening (Side Cladding)	7		
4.2.4 Side Lap Fastening	8		
4.2.5 Pierced Fastening	8		
4.2.6 Fastener Selection & Frequency	8		
4.3 Concealed Fix Fastening	10		
4.3.1 Klip-Lok & Klip-Tite Installation	11		
- Fastening clips for Klip-Lok & Klip-Tite	11		
- Hip and Valley fastening	11		
- Engaging Side-laps and Direction of Clipping	14		
4.3.2 Brownbuilt Installation	15		
-Fastening Clips for Brownbuilt	15		
- Button punching	16		
- Suspended Sheeting	16		
4.3.3 Concealed Fastened Cladding	16		
4.4 Stop Ending	16		
4.5 Lipping	17		
4.6 End Lapping	18		
4.7 Step-lap/Expansion Detail	19		
4.8 Expansion	19		
5. Flashing	19		
5.1 Longitudinal Flashing	19	2.1 Roof and Wall Sheeting Specification	3
5.2 Transverse Flashing	19	2.2 Compatibility of materials	6
5.3 Fastening Frequency for Transverse Flashings	21	4.1 Fastener Frequency and Location	8
5.4 Flashing around Roof Protrusions	21	4.2.1 Pierced -Fix Fasteners sheeting	9
5.5 Pipe Penetrations	21	4.2.2 Classification of Fasteners & Coating thickness	10
		4.2.3 Concealed-Fix sheeting Fasteners	10
		4.8 Coefficient of Expansion	19
		5.3 Fastener Frequency for Transverse Flashing	21
		9.1 Spans for Convex sheeting	24
		9.2 Spans for Concave sheeting	24
		10.1 Translucent sheeting availability	25
		- Requirements for Insulation blankets	26
		12.1 Drainage table	28
		13.1 Gutter sizes	28
		13.2 Rainfall intensities	29

TABLES

1. Introduction

TOTAL ROOFING SOLUTIONS FROM GRS

Global Roofing Solutions (GRS) is a private company, registered in South Africa, and consisting of two leading South African roofing material manufacturers Brownbuilt Metal Sections (established in 1964) and HH Robertson (established in 1958), making it one of the largest independent metal roofing companies in South Africa. Both Brownbuilt and HH Robertson are household names for the manufacture of commercial and industrial steel roof covering and wall cladding profiles (concealed fix and pierced fix), steel floor decking profiles, and lightweight metal roof tiles.

This Roofing and Walling Installation Manual has been prepared as a general reference to the correct installation of the Global Roofing Solutions wide range of metal roofing and cladding profiles.

It is stressed that the detail applies only to metal roofing and/or walling manufactured by GRS and marketed under their specific brand names.

Recommendations are based on comprehensive testing of specific G.R.S. profiles, thicknesses and finishes and should only be used for the nominated products as indicated.

The Manual supplements the detailed recommendations and procedures provided in individual product literature, which should also be consulted as appropriate. Other references which may need to be consulted, depending on the purpose include the latest additions of:

SANS 10237 : 1991 – "Code of Practice- Roof and Slide Cladding",

SANS 0160 : 1989 – "The general procedure and loadings to be adopted for the design of buildings".

SANS 6400 : 1990 – The application of the National Building Regulations.

GRS roofing/cladding products are engineered to perform as specified if installed and fastened in accordance with the recommendations in this and other relevant literature.

In general, the recommendations in this manual are for wind conditions designed for an ultimate uplift load of 1.6kN/m². For information on cyclonic wind conditions consult your nearest G.R.S. office.

A glance at the content page will indicate the range of topics included as a result of trade surveys. The manual is structured so that information on a particular product can be obtained without the necessity to search from cover to cover.

Recommendations such as those contained in Chapter 5, "Flashing and Capping" are based on standard roofing trade practices and demonstrate the various G.R.S. profiles and provide a weatherproof roof. The success of these systems obviously rely on good workmanship and materials.

G.R.S. is confident that the manual will prove useful to the professions and trades concerned with the specification and application of the wide range of G.R.S. metal roofing and cladding profiles available to the building and construction industry. As innovation is always to the fore in the roofing trade, G.R.S. would be pleased to receive comments and suggestions for the improvement of this manual.



2. Sheet Selection

2.1 Product Range Data







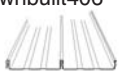

G.R.S. range of steel roofing and cladding includes the profiles listed in Table 2.1 and are available in various finishes:

- A) Galvanised
- B) Pre-painted finishes
- C) 55% Aluminium Zinc Alloy coated material
- D) Aluminium Mill Finish
- E) Aluminium pre-painted finishes

For selected profiles, metals like stainless steel, aluminium and copper are available. However, loadspan tables differ from Table 2.1. Consult your nearest G.R.S. office.

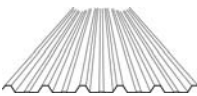
Table 2.1 lists general information to enable profile selection. Please refer to individual product literature for detailed specifications.

TABLE 2.1 ROOF AND WALL SHEETING SPECIFICATION

Profile	Thickness including Coating mm	kg/m ²	Cover Width mm	Sheet Depth mm	Recommended Min. Roof Slope	Rec. Support Centres			Roof cantilever	
						Roofs		Walls	Unstiffened	Gutter fixed to every pan. Max sheet length 13m
						Internal	End	Internal		
Brownbuilt406 [®] 	0.58	8.16	406	48	1°	1800	1500	2700	200	450
	0.8	10.26			Refer	2700	2400	3000	300	600
drainage table										
Klip-Lok 406 [®] 	0.5	5.84	406	41	2°	2000	1700		180	400
	0.58	6.78				2500	2100		260	600
	0.47	5.31			Refer	2000	1700		180	400
	0.53	5.98			drainage table	2300	1900		200	450
Klip-Lok 700 [®] 	0.5	5.5	700	41	2°	2000	1700		180	400
	0.58	6.6				2500	1800		260	600
	0.47	5.1			Refer	1900	1600		150	350
	0.53	5.7			drainage table	2300	1900		180	400
Klip-Tite [®] 	0.5	5.5	700	41	2°	2000	1700		180	400
	0.58	6.6				2500	1800		260	600
	0.47	5.1			Refer	1900	1600		150	350
	0.53	5.7			drainage table	2300	1900		180	400
Zip-Tek 420 [®] 	0.58	6.63	420	68	1°	2500	2100			
	0.55	6.0			Refer	2300	1900			
	0.53	5.8			drainage table	2300	1900			
IBR 890 	0.5	5.42	890	37	5° for sheet	2200	2100	3100	270	
	0.58	6.28			lengths up to 30m,	2600	2300	3400	300	
	0.47	4.92			7.5° for sheet	2100	2000	3100	270	
	0.53	5.75			lengths above 30m	2600	2300	3400	300	
IBR 686 	0.5 (FH)	5.48	686	37	5° for sheet	1800	1700	2750	350	
	0.58	6.36			lengths up to 30m,	2100	1800	2950	450	
	0.8	8.77			7.5° for sheet	2500	2300	3600	550	
	0.47				lengths above 30m	1800	1700	2750	350	
	0.53					2100	1800	2950	450	
Nu-Rib 	0.5 (FH)	4.93	762	28.6	7.5° for sheet	1550	1300	2200	350	
	0.58	5.72			lengths up to 30m,	1650	1400	2350	450	
	0.8	7.89			10° for sheet	1900	1600	2750	550	
	0.47	4.61			lengths above 30m	1550	1300	2200	350	
	0.53	5.22				1650	1400	2350	450	
Corrugated 10.5 	0.5 (FH)	4.93	762	17.5	7.5° for sheet	1100	900	1500	200	
	0.58	5.72			lengths up to 30m,	1100	900	1500	200	
	0.8	7.89			10° for sheet	1350	1200	1800	250	
	0.47	4.61			lengths above 30m					
	0.53	5.22								

CONCEALED FIX ROOF SHEETING & CLADDING

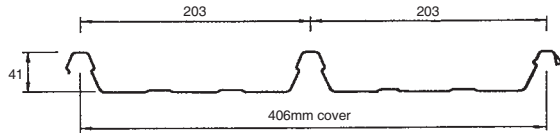

KLIP-LOK 406®

A concealed fix profile with a unique double interlocking side lap makes this profile a very fast installing roof sheet. This profile is ideally suited to low roof pitches. Manufactured from certified high yield steel or special grade aluminium making it lighter and stronger.

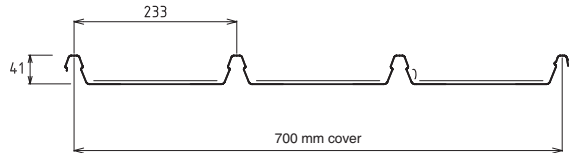

KLIP-TITE®

A rigid profile with improved properties providing improved clipping and wind-uplift resistance through its unique shape and transverse stiffeners.



ZIP-TEK 420

A deep trough concealed-fix standing seam profile suited for low pitch roofs and is manufactured from commercial quality mild steel or Aluminium.

Note:

At 1:50 (1°) slope, all roof supports must be in the same plane as slight variations can result in a zero or negative fall. This may even occur after completion of the building as a result of timber warping, shrinkage or from settlement. Where it is possible it is wise to design for a minimum of 1:30 (2°) slope to insure a positive fall and avoid any danger of "ponding" which can lead to a reduced service life, particularly in coastal areas. The maximum support spacings listed in Table 2.1 are based on the ability of sheeting to withstand wind loads applicable to enclosed buildings situated in average suburban or industrial areas with sheeting fastened as per Chapter 4. These wind loads, also concentrated loads, are determined in accordance with SANS 10237 – 1991 "Code of Practice Roof and Side Cladding".

For details of support spacings for conditions other than shown in tables refer to individual product literature.

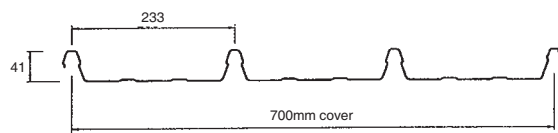

KLIP-LOK 700®

Similar to Klip-Lok 406 but wider. The sheet is even faster to install yielding greater savings. The profile is ideally suited to low roof pitches. Manufactured from certified high yield steel making it lighter and stronger.

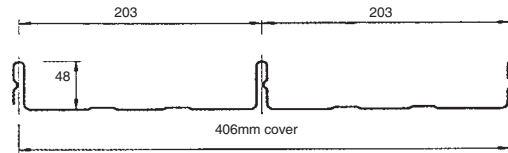

BROWNBUILT®

A concealed fix standing seam roofing which is fixed with concealed clips (no holes are made in the sheet) and is especially suited for low roof pitches. Manufactured from commercial quality mild steel, aluminium and copper.

PIERCED FIX ROOF SHEETING & CLADDING



IBR 890

A trapezoidal profile wider than conventional sheets to reduce the number of side laps and speed up installation. Manufactured from certified high yield steel making it lighter and stronger.

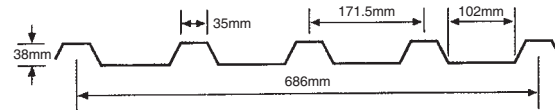

IBR 686

The trapezoidal flute design still offers the optimum strength, mass and load span characteristics compared to alternative profiles.

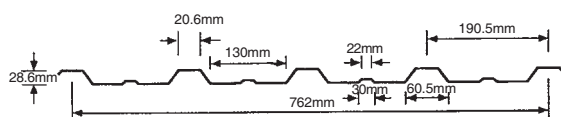

NU-RIB 762

This economical profile effectively bridges the gap between corrugated and IBR profiles.

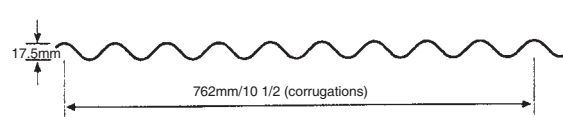

CORRUGATED 10.5

Corrugated 10.5 has a tranquil appearance, it is relatively light, easy to handle and provides an economical coverage per unit mass.

2.2 Wind Forces on Roofs

Winds create considerable forces on both the upper surfaces and the underside of a roof. These forces may take the form of positive or negative pressure and must be considered in the design and fixing of a roof.

Generally the greatest wind forces imposed on roofs are due to suction (negative pressure) tending to lift the roof cladding from its framing and the entire roof structure from its supports. As the dead weight of roofing materials is relatively small, the suction forces must be resisted by the roof fasteners.

It is equally important that the battens and roof framing be adequately fastened to the rafters and walls, and that under extreme conditions the wall framing be anchored to the footings.

When overhangs are used, the combined effect of push underneath and pull from above needs to be calculated and allowed for in the spacings of purlin centres. This will apply to overhangs at eaves and barges.

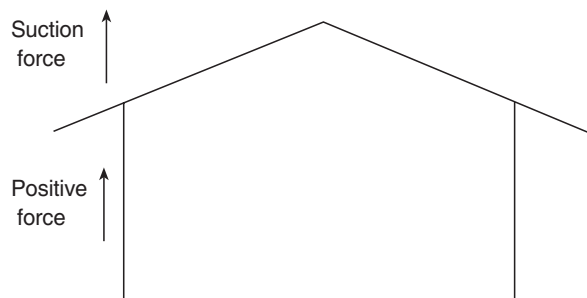

2.3 Codes and Performance Tests

SANS 10237 – 1991 "Code of Practice Roof and Side Cladding", lays down the performance standards which any metal roofing medium must satisfy. G.R.S roofing profiles satisfy all the requirements of this standard.

These include the ability of the roof to resist wind uplift forces and concentrated loads with an appropriate factor of safety. The Code provides that the compliance of metal roofing products with the performance specifications shall be checked by stringent proof tests, carried out in accordance with a procedure which is laid down in the Code. Such proof tests have been carried out on all G.R.S. roof claddings and the results have been used in the preparation of the fastening and installation recommendations in this manual.

2.4 Maintenance Procedures.

As with any product, care and the attention during service is well repaid by extending service life.

Regular cleaning of surfaces by hosing and the removal of accumulated debris such as leaves, dirt, pollution fallout etc., will help prevent the setting up of localised areas where accelerated corrosion might occur. In particular accumulations of wind-borne salty deposits, i.e. under eaves overhangs, in coastal localities can have a particularly aggressive effect on steel sheeting.

On the other hand, being fairly soluble, these salty deposits are readily removed by a gentle hosing with clean water. It may be advisable to provide permanent protective coating to underside of overhangs.

2.5 Run-off water

Run off from a prepainted finish, polycarbonate or inert material will accelerate corrosion on a galvanised surface below. If the water is allowed to drip rather than flow this situation is exaggerated which will show spot corrosion. Typical inert roof materials are, aluminium, slate, pre-painted sheets, fibreglass acrylic, glass and polycarbonate. Also see table 2.2 on page 6 for compatibility of materials (Metals)

3. General Care and Handling

3.1 Care and Storage Prior to Installation

G.R.S. roof and wall sheeting is normally transported to site in strapped bundles. Bundles should be neatly stacked clear of the ground and if left in the open should be protected from rain and moisture with waterproof covers and adequate ventilation.

ON NO ACCOUNT SHOULD SHEETING IN ANY SURFACE FINISH, THAT IS BUNDLED OR NESTED IN STACKS, BE ALLOWED TO GET WET.

Rain or condensation is easily drawn between the surfaces of nested sheets by capillary action or driven in by wind action, and as this trapped moisture cannot evaporate normally it can cause deterioration of the coating (i.e. White Rust) which may lead to a reduced life expectancy or poor appearance. If packs become wet the sheets should be separated without delay and the surface moisture removed with a clean cloth. The sheets should then be stacked so that air circulation completes the drying process.

3.2 Handling on Site

On large building projects handling time can be reduced by lifting sheet bundles, by crane, direct from the delivery truck onto the roof frame. A spreader beam and fabric slings should be used to support the sheets while lifting. Sheets should be spread out in small bundles on roof frame to prevent overloading, and

Table 2.2 Compatibility of Material (Y* = Drainage acceptable, direct metal contact not acceptable. N= Not acceptable)

Upper surface materials / Lower surface materials	Galvanised steel	Zincalume Colorbond XRW, Metallic and Ultra	Colorbond Stainless & Stainless Steel	Aluminium	Copper	Zinc	Monel	Lead	Glazed tiles, glass & plastic	Unglazed tiles (concrete)
Galvanised steel	Y	N	N	N	N	Y	N	Y*	N	Y
Zincalume Colorbond XRW, Metallic and Ultra	Y	Y	Y*	Y	N	Y	N	N	Y	Y
Stainless Steel	Y*	Y*	Y	Y*	Y*	Y*	Y*	Y*	Y	Y
Aluminium	Y	Y	Y*	Y	N	Y	N	Y*	Y	Y
Copper	Y*	Y*	Y*	Y*	Y	Y*	Y	Y	Y	Y
Zinc	Y	N	N	N	N	Y	N	Y*	N	Y
Monel	Y*	Y*	Y*	Y*	Y	Y*	Y	Y	Y	Y
Lead	Y*	Y*	Y*	Y*	Y*	Y*	Y*	Y	Y	Y

strapped to purlins to prevent them being lifted by wind. Where mechanical handling facilities are not available sheets have to be unloaded by hand and passed up to the roof one at a time.

To preserve the surface finish, sheets should be handled with care. Do not slide sheets over rough surfaces or over each other and do not drag tools, scaffold poles, etc. over laid sheets.

3.3 Walking on Roof Sheeting

When walking along a length of roof sheeting walk in the pans of Klip-Lok®, Klip-Tite®, Brownbuilt®, IBR and on at least two corrugations of corrugated. When walking across the length of roof sheeting walk over or close to the purlins.

Generally keep load evenly distributed over the soles of both feet and try not to concentrate load on heel or toe.

Always wear soft soled shoes when walking on roof sheeting.

Sheets taken freshly from packs may have the residue of rolling fluid on the surface and care should be exercised when walking over newly laid sheets until the fluid has evaporated.

3.4 Cutting sheets on Site

If it is necessary to cut sheets on site, care should be taken to avoid cutting over other sheeting. Hot particals cause damage to finishes (especially pre-painted finishes). Use a power saw with cold cutting blades. This produces less hot metal particals and burrs as opposed to carborundum discs. Metal particles on the roof sheeting are detrimental to the life of the roof and leave unsightly red rust patches.

Note: Cut sheets to be deburred and coloured sheets to be touched up.

3.5 Cleaning up

Normal installation procedures for roofing and flashing using self-drilling screws, drills, saws or angle grinders will usually deposit metallic particles onto the roof area. These metallic particles and all other debris including, rivet shanks, nails, screws, nuts, cuttings, swarf, etc. should be swept from the roof sheeting,

flashings and gutters as soon as possible, certainly at the end of each day's work and particularly on completion of the roof installation.

Corrosion and possible failure of the pre-painted or galvanised coating may take place when iron, lead or copper based materials are allowed to remain in contact with the coated surfaces subject to moist or condensation conditions.

3.6 55% Aluminium Zinc Alloy Coated Steel

Soft shoes and gloves should be worn when handling this material to avoid discoloration caused by oily residue from the human body.

4. Installation Procedure

4.1 General Procedure

The installer must ensure that the steel structure is suitable for installation of sheeting. Particular attention should be paid to squareness of structure and alignment of purlins and girts, which should be in the the same plane and that purlin rotation is limited to the guidelines stipulated in SAISC Red Book.

When lifting sheets onto the roof frame ready to commence laying and fastening, care should be taken to make sure all sheets are the correct way up and all have the overlapping side towards the edge of the roof from which installation should commence. Otherwise sheets will have to be turned over or turned end for end. Sheet bundles should be placed over or near trusses and not at mid-span of purlins.

The first sheet should be positioned with particular care before fastening, to ensure that it lies straight and square and is correctly located in relation to other building elements:

- a) Transversely in relation to the barge fascia or side-wall, bearing in mind the type of flashing or capping treatment to be used.
- b) Longitudinally in relation to the gutter and ridge or parapet or transverse wall. Roof sheets should overhang about 50 mm into gutters.

When the first sheet is fastened into position a string line can be stretched across the lower end

of the roof alignment. The line and first sheet then become locators for quick placing and aligning of subsequent sheets. However, periodic checks should be made during the installation of each roof area, by measuring across the width of the fastened sheeting, at the top and again at the bottom of the sheet run. This is to ensure that any tendency to creep or fan is controlled. At some stage, say half-way, a measurement should also be made from both the top and bottom of the fastened sheeting to the far side or finishing line of the roof area. This is to check that the fastened sheeting is parallel to the finishing line.

If the building is not square then tapered flashing is required. Fanning or stretching of the sheet is not permitted to allow for a building that is not square.

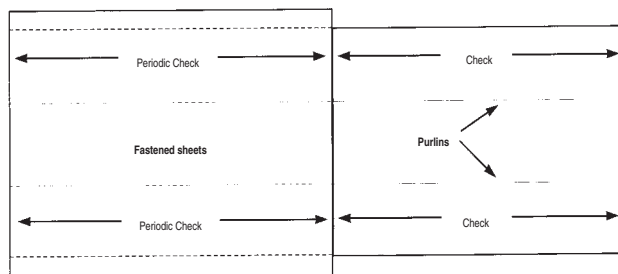

4.2 PIERCED FASTENING

The pierce fastened Corrugated sheet has a one and a half corrugation side lap, whereas IBR has a one flute side lap as shown in the following illustrations.

4.2.1 Side-Lapping

IBR 686 & 890 and Nu-Rib



Corrugated



When placing and locating each sheet the side lap over the previous sheet should be held firmly in place until each end of the sheet has been fastened. This can be simply and easily achieved by clamping the lapped sheets with a pair of vice grips.

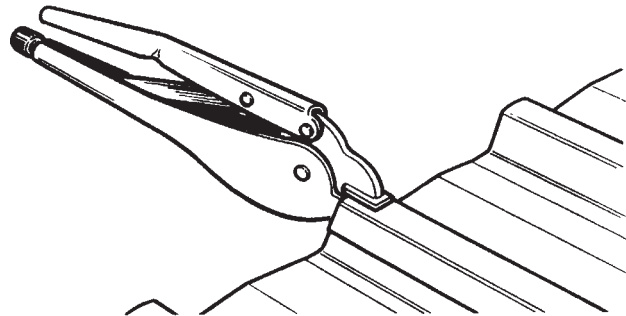

The procedure is to place the sheet being installed into position and lapped with the previous sheet as shown above. The sheet is then located for

longitudinal alignment and with the lap snugly nested the vice grips are clamped onto one end, preferably the high end of the lap as shown.

This holds the lap in place at one end of the sheets while the lap on the other end is snugly nested and the sheet fastened. The vice grips also holds the sheet in longitudinal alignment during fastening.

Each sheet should be fully fastened before proceeding to the next sheet. The fastening sequence should be from the centre of the sheet towards the sides. The side lap with the preceding sheet should be fastened last.

Pierced fastening may be achieved by the use of screws located in the crest or valley (cladding only) of the sheet corrugations or flute. See Tables 4.1, 4.2.1 and 4.2.2 for recommended screws and nails.

4.2.2 Crest Fastening

Fastening through the crest of the corrugations or flutes is recommended for Corrugated and IBR roofing and can also be used on cladding applications. The fasteners should be positioned in the centre of a corrugation or flute and must be driven perpendicular to the support.

Typical Crest fastener detail



Corrugated to steel support

Main fastener

Side-lap fastener



IBR to timber support

4.2.3 Valley Fastening (cladding only)

The method of pierced fastening through the valley between corrugations or flutes of Corrugated or IBR is recommended for wall cladding only.

Fasteners located in the valley of wall sheeting are less conspicuous and do not break the clean neat line of modern steel cladding. Valley fasteners are also tightened on an area of sheeting hard against the support so there is no risk of the profile being deformed. However, valley fastened Corrugated and IBR require a side lap fastener in each lap at each support and at midspan for fastener frequency and location – see Table 4.1

Valley fastening is not recommended for roofing application of Corrugated or IBR.

Typical Valley Fastener Detail with Lap Fastener Over Support at Side Lap (side cladding only)

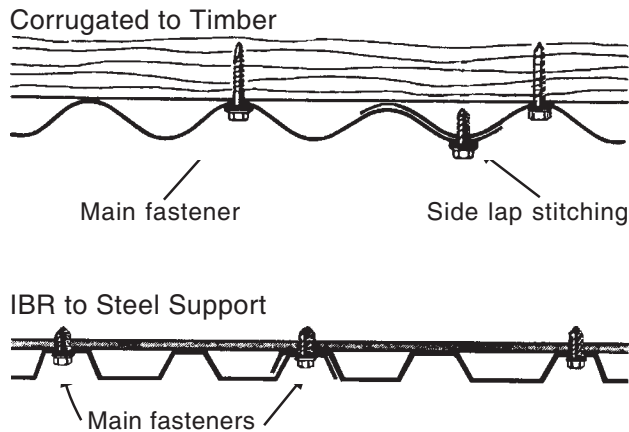

4.2.4 Side Lap Fasteners

Lap fastening (stitching) between supports is recommended to hold the side laps of roof and wall sheeting firmly together and maintain a completely waterproof joint. This applies particularly to roof sheeting which may be subjected to occasional roof traffic and to wall sheeting when installed over maximum spans.

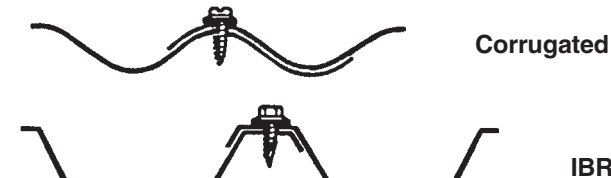

Maximum spacing of side lap fasteners should be 600mm centres for roof sheeting. For side-cladding it should be on the girt and midway between girts.

Side lap stitching on polycarbonate is essential. Use peel rivet & bonded EPDM washer.

4.2.5 Pierced Fasteners

The recommended fasteners listed in Table 4.2.2 have been designed for pierced fastening G.R.S IBR and Corrugated roofing and cladding products to timber or steel supports. G.R.S recommends that fasteners be selected having regard to the design life of the structure.

Specifiers must take care to specify fasteners of at least similar life expectancy to the cladding material

Fasteners should be tightened only until the washer is gripped firmly enough to provide a weatherproof seal. The fasteners should not be overtightened as this will deform the sheet.

All holes for fasteners should be drilled and not punched. Swarf and metal dust shall be removed before fixings and washers are positioned. In the case

of pre-coated sheeting, sheets should not be drilled in packs, drilling in packs causes hot swarf and metal dust to be trapped between the sheets and to embed into the surface coatings, which could cause corrosion of the sheet after it has been installed.

4.2.6 Fastener selection and frequency

Table 4.1 shows the recommended number of fasteners per sheet, at each support, and their location across the sheet for both crest and valley fastening.

This frequency of fastening is to meet the conditions and support spacing listed for Table 2.1. The frequency of side lap fasteners is also given here.

When selecting fasteners, one should consider the class of fasteners used, thereby ensuring the life expectancy of the fasteners is at least similar to that of the cladding. Refer to SANS1273: Fasteners for roof and wall coverings (based on AS3566 and ISO9223) Table 4.2.1 on page 10 lists the corrosion resistance classes and designations for fastener selection.

Fastener length for sheet & insulation

Where insulation is installed between purlin and sheeting, the length of screws should be increased depending on the compressed thickness and density of the insulation.

For metal purlins - The drill point and 3 threads should at least protrude past the support but the shank protection must not reach the support.

For Timber purlins - The screw should penetrate the timber by the same depth recommended as if there was no insulation (45mm).

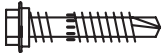



TABLE 4.1 Fastener Frequency and Location



Support Location	Fasteners Per Sheet	Location of Crest Fasteners for Roofs and Valley Fasteners for Cladding	Sidelap Fastener Spacing	Support Location	Fasteners Per Sheet	Location of Crest Fasteners for Roofs and Valley Fasteners for Cladding	Sidelap Fastener Spacing
INTERNAL SUPPORTS	3	CORRUGATED Crest (Roofing)	Mid Span	INTERNAL SUPPORTS	3	IBR & Nu-Rib Crest (Roofing)	Max 600 mm centres
	5	Valley (Cladding)			3	Valley (Cladding)	
END AND LAP SUPPORTS	5	Crest (Roofing)	Max 600 mm centres	END AND LAP SUPPORTS	5	Crest (Roofing)	Max 600 mm centres
		Valley (Cladding)			5	Valley (Cladding)	

Table 4.2.1 Pierced-Fix sheeting Fasteners

IBR 686, IBR 890 (Supa-Clad), Nu-Rib and Corrugated fixed to Cold Rolled Steel 1 to 4,5mm thick

IBR, Supa-Clad & Nu-Rib	Crest fastening	Hex Flange Head + EPDM Seal self drilling No. 3 drill point No.12-14 x 65mm long	
Corrugated	Crest fastening	Hex Flange Head + EPDM Seal self drilling No. 3 drill point No.12-14 x 38mm long	
IBR, Supa-Clad, Nu-Rib & Corrugated	Valley fastening	Hex Flange Head + EPDM Seal self drilling No. 3 drill point No.12-14 x 25mm long	



IBR 686, IBR 890 (Supa-Clad), Nu-Rib and Corrugated fixed to Hot Rolled Steel 6 to 12,5mm thick

IBR, Supa-Clad & Nu-Rib	Crest fastening	Hex Flange Head + EPDM Seal self drilling No. 5 drill point No.12-24 x 68 mm long	
Corrugated	Crest fastening	Hex Flange Head + EPDM Seal self drilling No. 5 drill point No.12-24 x 53 mm long	
IBR, Supa-Clad, Nu-Rib & Corrugated	Valley fastening	Hex Flange Head + EPDM Seal self drilling No. 5 drill point No.12-24 x 38mm long	

IBR 686, IBR 890 (Supa-Clad), Nu-Rib and Corrugated fixed to Light Steel Frame 0,5mm thick

IBR, Supa-Clad & Nu-Rib	Crest fastening	Contact GRS	
Corrugated	Crest fastening	Contact GRS	
IBR, Supa-Clad, Nu-Rib & Corrugated	Valley fastening	Contact GRS	

IBR 686, IBR 890 (Supa-Clad), Nu-Rib and Corrugated fixed to Timber Purlins

IBR, Supa-Clad & Nu-Rib	Crest fastening	Hex Flange Head + EPDM Seal self drilling Type 17 drill point No.12-11 x 85mm long	
Corrugated	Crest fastening	Hex Flange Head + EPDM Seal self drilling Type 17 drill point No.12-11 x 65mm long	
IBR, Supa-Clad, Nu-Rib & Corrugated	Valley fastening	Hex Flange Head + EPDM Seal self drilling Type 17 drill point No.12-11 x 50mm long	

STITCHING SCREWS

IBR, Supa-Clad, Nu-Rib, Corrugated & Flashings	Stitching	Hex Flange Head + EPDM Seal self drilling Stitching point No.14-14 x 20mm long	
---	-----------	--	---

Note: Where insulation is installed between the purlin and the sheeting, the length of screws increase depending on the compressed thickness and density of the insulation. For steel purlins at least 3 screw threads should protrude past the support. For timber purlins the screw should penetrate the purlin by the same depth recommended as if there was no insulation.

TABLE 4.2.2 CLASSIFICATION, COATING THICKNESS AND DESIGNATION OF CORROSION RESISTANCE

Fastener Class	Coating type	Minimum local metallic coating thickness	Passivation	Atmosphere of intended use
Class 2 fasteners	Electroplated zinc	12µm	Type C	General use in other than external applications where significant levels of condensation occurs. External: Urban inland or mild environments.
	Mechanically plated zinc	17µm	Type C	
	Mechanically plated zinc/tin	12µm	Type C	
Class 3 fasteners	Electroplated zinc	30µm	Type A	External use in mild, moderate . industrial or marine environments. Corrosivity categories C2 and C3 classified in accordance with ISO 9223.
	Mechanically plated zinc	40µm	Type A	
	Mechanically plated zinc/tin	25µm	Type A	
Class 4 fasteners	Mechanically plated zinc/tin	45µm	Type A	External use in severe marine or industrial environments. Corrosivity category C4 classified in accordance with ISO 9223

Table 4.2.3 Concealed-Fix sheeting Fasteners

Klip-Lok 406, Klip-Lok 700, Klip-Tite and Brownbuilt fixed to Cold Rolled Steel 1 to 4,5mm thick

	Screws/Clip	Wafer Head Self Drilling Screws	
Klip-Lok 406	2	No. 10-16 x 16mm long PH2 No.3 drill point	
Klip-Lok 700	3	No. 10-16 x 22mm long PH2 No.3 drill point	
Klip-Tite	3	No. 10-16 x 45mm long PH2 No.3 drill point	
Brownbuilt	2	No. 12-14 x 65mm long PH3 No.3 drill point	
		No. 12-14 x 85mm long PH3 No.3 drill point	

Klip-Lok 406, Klip-Lok 700, Klip-Tite and Brownbuilt fixed to Hot Rolled Steel 6 to 12,5mm thick

	Screws/Clip	Wafer Head Self Drilling Screws	
Klip-Lok 406	2	No. 12-24 x 38mm long PH3 No.5 drill point	
Klip-Lok 700	3	No. 12-24 x 65mm long PH3 No.5 drill point	
Klip-Tite	3		
Brownbuilt	2		

Klip-Lok 406, Klip-Lok 700, Klip-Tite and Brownbuilt fixed to Light Steel Frame Purlins 0,5mm thick

	Screws/Clip	Contact GRS	
Klip-Lok 406	2		
Klip-Lok 700	3		
Klip-Tite	3		
Brownbuilt	2		

Klip-Lok 406, Klip-Lok 700, Klip-Tite and Brownbuilt fixed to Light Steel Frame Purlins 0,5mm thick

	Screws/Clip	Wafer Head Self Drilling Screws	
Klip-Lok 406	2	No. 10-11 x 45mm long PH2 with Type 17 point	
Klip-Lok 700	3		
Klip-Tite	3		
Brownbuilt	2		

Note: Where insulation is installed between the purlin and the sheeting, the length of screws increase depending on the compressed thickness and density of the insulation. For steel purlins at least 3 screw threads should protrude past the support. For timber purlins the screw should penetrate the purlin by the same depth recommended as if there was no insulation. Where Fibreglass insulation blankets in excess of 50mm is used over purlin, refer to Table.....for fixing details.

4.3 CONCEALED FASTENING

For Zip-Tek installation details refer to GRS Klip-Lok®, Klip-Tite® and Brownbuilt® concealed fix profiles follow the same general installation procedure as described in Chapter 4.1, except at commencement of installation a row of fastening clips are positioned

and fastened to the supports before the first sheet can be located over them and locked in position.

As there are major differences in the clipping assembly and locking of Klip-Lok®, Klip-Tite® and Brownbuilt® the installation of each is described separately on page 14.

Fastener length for sheet + insulation

Where insulation is installed between purlin and sheeting, the length of screws should be increased depending on the compressed thickness and density of the insulation.

For metal purlins - The drill point and 3 threads should at least protrude past the support.

For Timber purlins - The screw should penetrate the timber by the same depth recommended as if there was no insulation (45mm).

4.3.1 Klip-Lok & Klip-Tite Installation

KL65 clips are used for concealed fastening Klip-Lok 406®. These clips are asymmetric having a short downturn on the interlocking rib upstand and a long downturn on the centre rib upstand. KL 700 clips are used for concealed fastening Klip-Lok 700® & Klip-Tite®. These clips have three upstands for fixing the male rib and the two centre ribs of the Klip-Lok 700® & Klip-Tite® sheet.

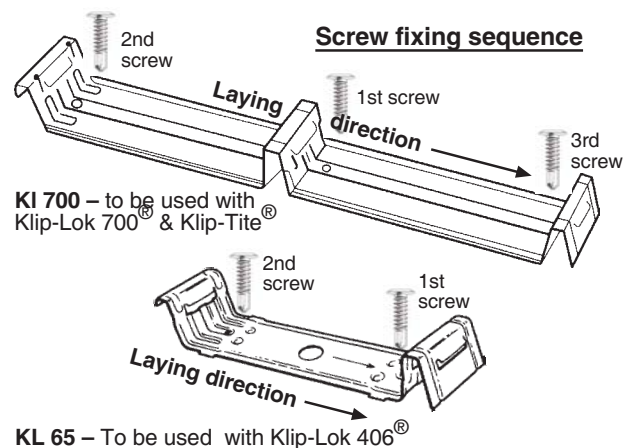

Recommended fasteners for Concealed fix products (REFER TO TABLE 4.4)

Fastening Clips

The KL 65 and KL 700 clips are fastened to the top of the support with two and three fasteners respectively, one located each end of the clip in the holes provided. Extra dimples are provided for secondary fastening in case a fastener breaks, a timber support splits or for additional fasteners in areas where the wind loading exceeds 1.6kN/m². Also, where additional fasteners are required in the case of thick insulation blankets.

Installation Procedures

Read in conjunction with chapters on Stop ending, Flashings and Bullnosing before commencing sheet installation.

Before commencing also ensure that end-spans, internal spans and cantilevers are not exceeding the maximums allowed. (See Table 2.1) Also ensure that hip & valley supports have been installed (see below). Also see how fixing clips are cut to fix rake-cut sheets

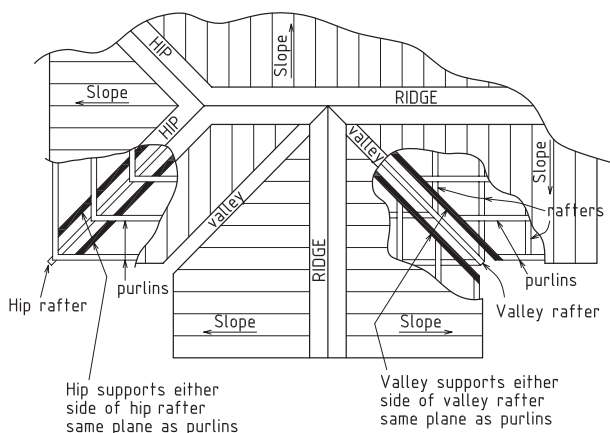

PLAN VIEW

This principle applies to both timber & steel structures.

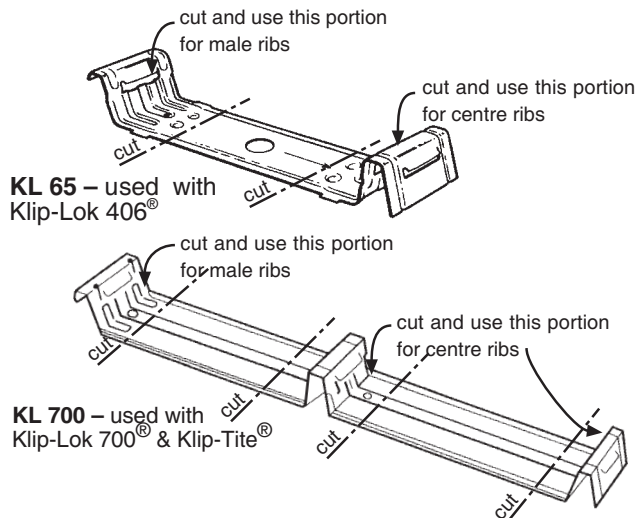

Note:

At rake-cut edges (hips & valley gutters) care should be taken that every rib is securely fixed down in this area with pieces cut from standard fixing clips.

Steps 1 to 5 illustrates Klip-Lok 406. The procedure for Klip-Lok 700 and Klip-Tite is the same. Read in conjunction with page 14

STEP 1

As described in the general procedures (Chapter 4.1), when lifting sheet lengths onto the roof frame, ready for installation, make sure all the sheets have overlapping female rib facing towards the side where fastening is to commence. The first run of KL65 or KL700 clips have to be located and fastened one to each support so that they will correctly engage in the female and centre ribs of the first sheet when it is located over them.

To do this, fasten clips to the purlins at each end of the sheet, having positioned them so that the first sheet will be in correct relation to other building elements. Align and fasten the remainder of the first run of clips using a string line or the first sheet as a straight edge. The Interlocking Rib upstand side of the clip must be on the outside edge of the roof supports and clips must be square to the sheeting. When laying Bullnose or Rib cap sheets please refer to Chapters 6 or 7 before proceeding. Fix positive if there are no flashings.

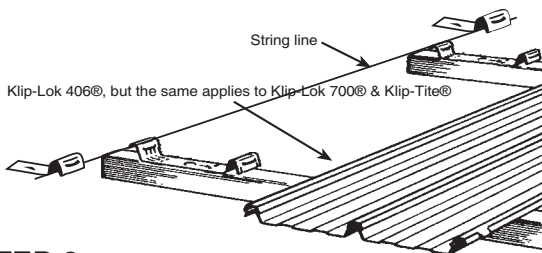

STEP 2

Locate the first sheet over the fastened run of clips, having positioned it longitudinally in relation to gutter overhang and then fully engage on clips with foot pressure applied to the centre and female ribs over each clip.

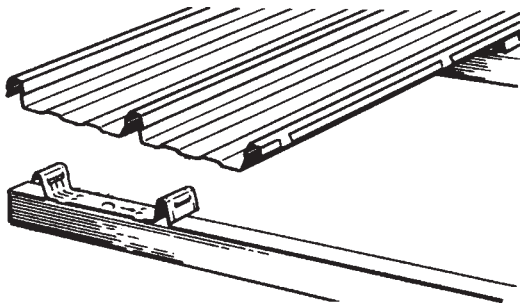

STEP 3

Position the next run of clips, one to each support, with the interlocking ribs upstand of the clips engaged over the male rib of the installed sheet. Do not step on the male rib. Step in the end pan and fasten the clip at the centre rib first, then fasten the clip at the male rib. Do not push or pull clips as they will not engage properly into the sheet.

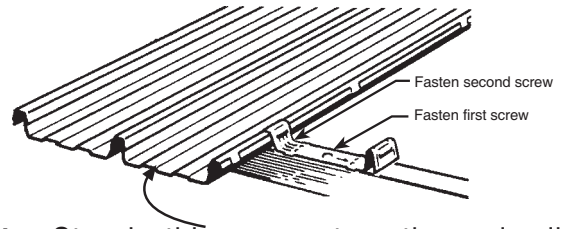

Note: Step in this pan, not on the male rib.

If the clip falls on one of the spurs spaced along the outer free edge of the male rib, the spur should be flattened with a blow from a rubber mallet to allow the clip to seat down over the rib.

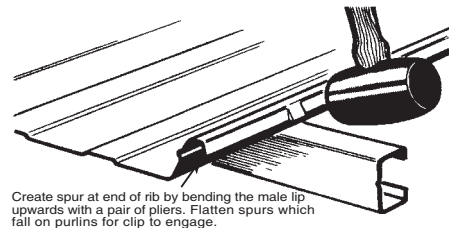

STEP 4

Place the second sheet over the second run of clips with the female rib overlapping the male rib of the first preceding sheet and the centre rib upstand of the clips.

Create a spur with a pair of pliers at end of sheet as indicated in sketch above and with a rubber mallet, close the female rib before engaging.

A string line stretched across the bottom alignment of sheets can be used to check that the end of the sheets are in line. The string line must be at a higher level than the depth of the profile to ensure that it is not pushed away when the sheet is positioned. Only then fully engage the interlocking ribs and the centre rib over each clip.

One foot should be in the tray next to the overlapping female rib and the other foot applying pressure to the top of the interlocking ribs at regular intervals. Also apply foot pressure to the top of the centre rib over each clip. See sketch for Klip-Lok 406® & 700® & Klip-Tite®.

When engaging sidelap, always walk from **one end to the other** (bullnose sheets walk from bullnose). Never walk from both ends to the centre.

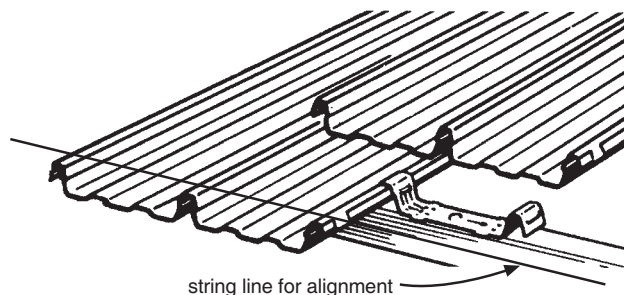

For complete interlocking, which is essential, the spurs of the underlapping male rib must be fully engaged in the shoulder of the overlapping female rib. A distinct "click" will be heard as the spurs along the edge of the male rib snap into the shoulder along the female rib.

When engaging Klip-Lok® & Klip-Tite® interlocking ribs, stand only on the sheet being installed. That is the overlapping sheet – not on the preceding sheet.

Install subsequent sheets by following steps 3 and 4 and make periodic checks for parallel as described in general procedure (Chapter 4.1)

On walling applications a rubber mallet should be used to fully engage the interlocking ribs and engage the centre rib over the clips. (Also see 4.3.3)

If no spur is visible, create one with a pair of pliers 20 mm from the end of the sheet and close the female rib \pm 300 mm before engaging.

STEP 5

If the space left between the last full sheet and fascia or parapet is more than a half sheet width, a sheet can be cut longitudinally leaving the centre rib complete, and this part of the sheet can be fully engaged onto a row of clips as for a full sheet.

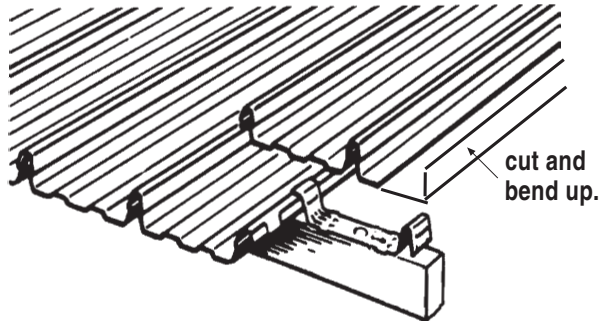

If the space left between the last full sheet and fascia or parapet is not a full sheet width, the last sheet needs to be cut and a dry pan formed along the full length of the sheet. This is achieved by measuring the width that the last sheet has to cover, add 40mm to the measured width, cut the sheet at that point over its full length and bend the sheet up to form a dry pan. This part of the sheet can be fully engaged onto a row of clips as for a full sheet.



Installing KL700 Clips with 50mm thick Fibreglass insulation

For insulation blankets thicker than 50mm, additional measures must be employed – see table on page 27

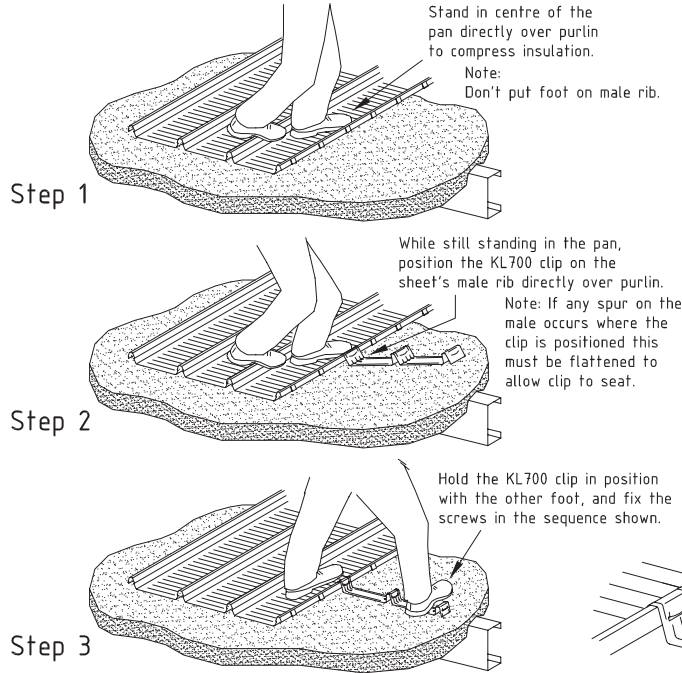

Installing KL700 Clip

1. Stand with a foot in the centre of the male rib's pan & over the purlin to compress the insulation.
2. Position the KL700 clip correctly over the male rib of sheet and directly over the purlin. If any spur of the sheet occurs where the KL700 clips are to be fitted these should be flattened beforehand.
3. While still standing in the sheet's pan, also stand on the KL700 clip as indicated, and while keeping it in the correct position fix the centre screw first. Then fix the screws of the sheet before fixing the outer screw.

Note: The same principles will apply when fitting the clip with rigid board insulation or without insulation.

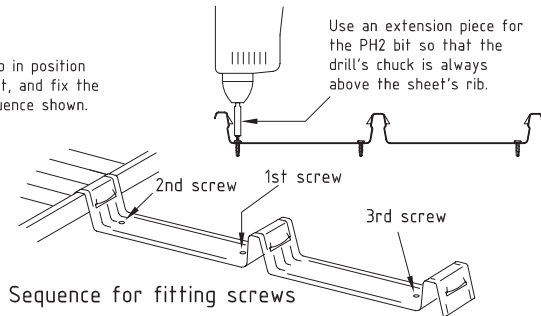

Engaging Sidelap

Note: Engage centre ribs of sheet to the clip first before engaging the side lap.

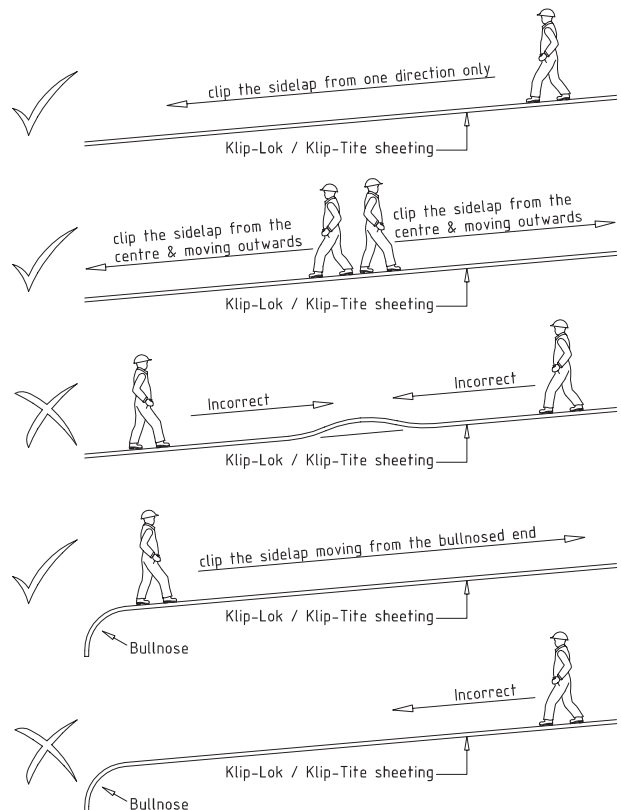
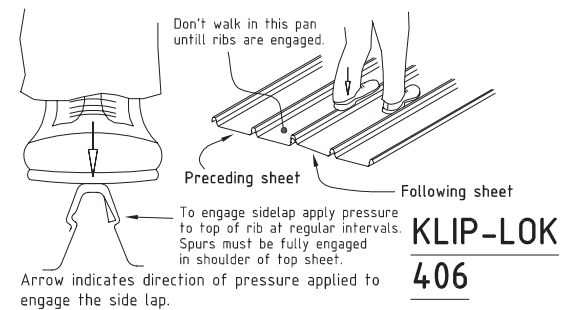
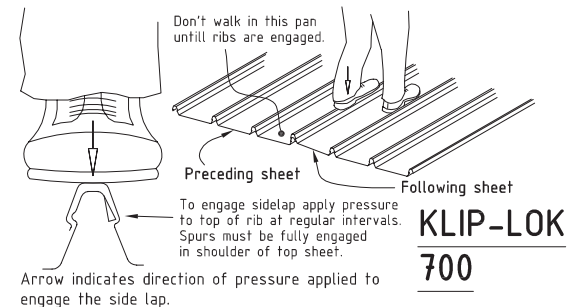
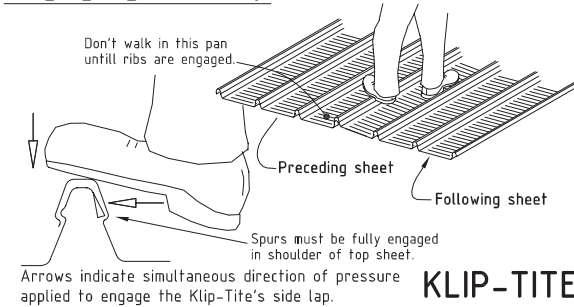

4.3.2 BROWNBUILT® Three types of clips are used for the concealed fastening of Brownbuilt® sheeting. A starting clip, a duplex clip and a finishing clip.

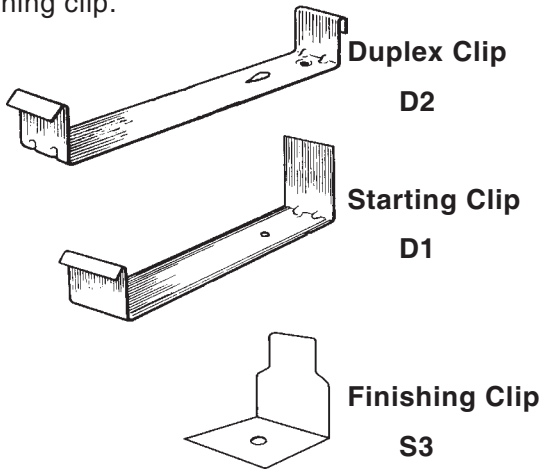

Recommended Fasteners for Brownbuilt® Clips (Refer to Table 4.2.3)

INSTALLATION PROCEDURES

Read in conjunction with Chapters on Stop ending, Flashings and Bullnosing before commencing sheeting.

STEP 1

As described in the general procedures (Chapter 4.1) when lifting sheet lengths onto the roof frame ready for installation, make sure all the sheets have the overlapping female rib facing towards the side where the fastening is to commence.

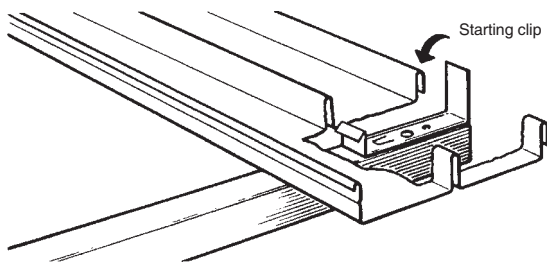

The first run of starting clips have to be located with the upstand side to the outer edge of each support so that they will correctly engage in the centre rib of the first sheet when it is located over them. Care must be taken in aligning and fastening of the first line of clips in relation to other building elements – using a string line or the first sheet as a straight edge. Once the first sheet is in place the outside leg of the starting clip must be bent down over the female rib of the sheet.

STEP 2

A run of duplex clips, one to each support, is now positioned over the male rib of the installed sheet and fastened to the supports with appropriate recommended fasteners.

Before these clips can be positioned the turn-over along the top of the male rib of the sheeting has to be locally flattened with a rib closing tool.

Rib Closing Sequence

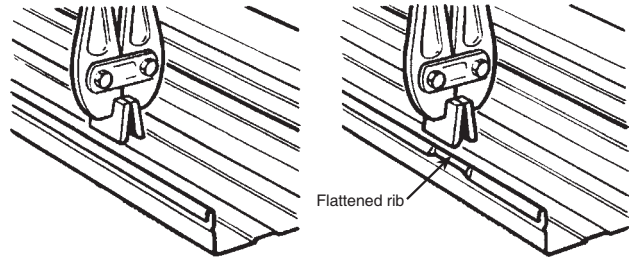

Clips for 2nd and successive sheets

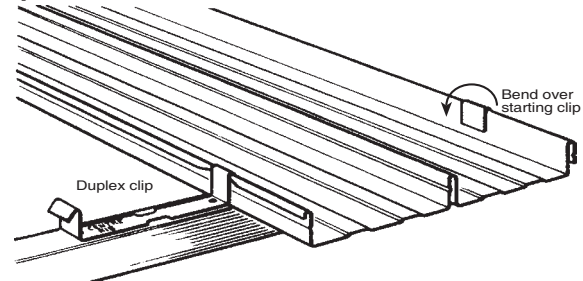

STEP 3

Place the next sheet in position by locating the female rib over the overlapping male rib of the preceding sheet and the fastened clips. When placing the sheet check the longitudinal location using a string line stretched across the bottom alignment of the sheeting.

Install subsequent sheets by following steps 2 and 3 and make periodic checks for parallel as described in general procedures (Chapter 4.1). It is recommended that periodic checks are made at intervals of every sixth sheet.

STEP 4

If the last sheet in the roof is a full width sheet a finishing clip can be positioned and fastened to each support before placing the last sheet. The narrow portion of the clip upstand is then folded down over the male rib after the last sheet has been positioned.

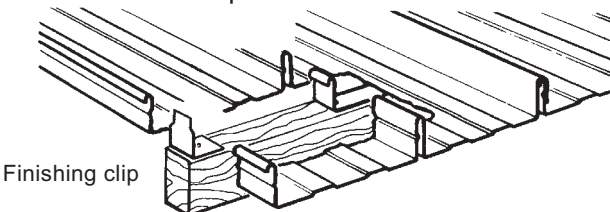

STEP 5

When all the sheeting is assembled in position and engaged with the fastened clips, the overlapping ribs are locked together by using a button punching tool.

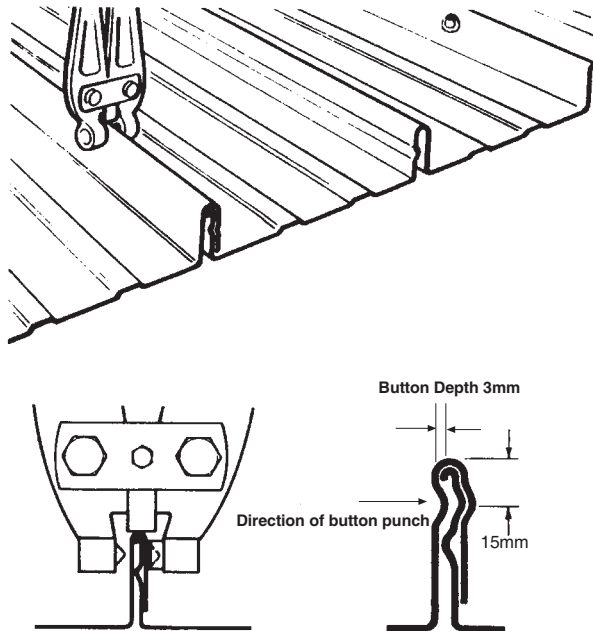

The overlapping female rib must be pressed down firmly onto the underlapping male rib before applying the button punch.

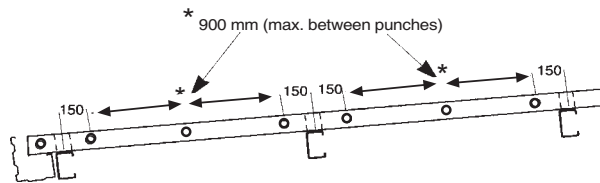

The spacing of punching along each interlocking rib should not exceed 900 mm and must be kept clear of the support to avoid punching over a clip. **Do NOT punch over clips.**

Punching to a string line guide stretched across the sheeting is recommended as with random punching, the appearance of the finished work can be marred.

The direction of Button Punching is extremely important as the indentation needs to be formed on the female side below the end of the male rib, see sketch above.

It is important that the Button Punch is set correctly and should be checked at least once a day while in use.

Button Punching Location and Frequency

For spans between supports spaced up to 1300 mm button punching should be applied 150 mm

each side of the duplex clips. For spans over 1300 mm an additional button punch is required at mid-span. Button punching for wind loading exceeding an uplift of 1.6kN/m², please contact GRS.

Suspended Sheeting

Brownbuilt sheeting are also used as economical roof and ceiling combinations for canopies, shop verandahs, link corridors and suspended roofs. Sheeting is laid in the opposite direction to the normal, commencing with the male rib at the verge.

Fixing is accomplished with H.9 clip assemblies on EVERY rib of the sheeting and holes for the 6 mm T-Bolts should be punched from the top and NOT DRILLED. It is essential that the toe of at least one purlin should face in the opposite direction to the others to prevent movement of the sheeting.

Brownbuilt 406 sheeting as suspended roof/ceiling

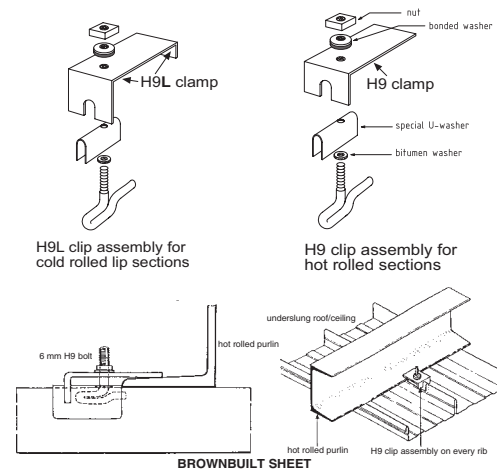

4.3.3 Concealed Fastened Cladding

Klip-Lok® and Klip-Tite® are not suited for side cladding. Brownbuilt® profiles however, may be used as walling or even on very steep roof pitches, and used as such, it should have at least one pierced-fix fastener through each pan to prevent its gravitational movement down the fastening clips. This fastener can be located into the top support under the flashing along the top of the sheeting.

4.4 Stop-ending

All G.R.S. roofing profiles, should be stop-ended at the high end, regardless of slope, to ensure that water, wind driven beneath the flashing will not drain into the building.

The stop-ending/turn-up operation should be carried out before the sheets are placed in position – this applies especially where head / parapet walls occur – although it can be done after installation if sufficient clearance is left at the top end of the sheets for operation of the turn-up tool.

Corrugated Iron

Corrugated Iron requires vice-grips or a shifting spanner, closed down to 2 mm, grip valley 20 mm in from end of sheet and turn up as far as possible.

Rake cut sheets ie: hips, can be stop ended with a shifting spanner or vice grips in the same manner as straight sheets.

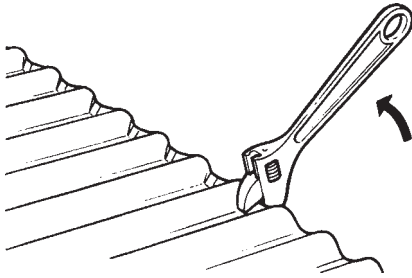

Klip-Lok®/Klip-Tite® Stop-Ending Procedure

If stop-ending is to be carried out after the installation of sheets the corner of the turn down of the female rib must be cut off. **Do not use the Klip-Lok 406® stopenders tool for the Klip-Lok 700®/Klip-Tite® profile because the pan width varies.**

Where rake cut sheets at hips have to be stop-ended, care must be taken to bend up full width of pan. This is best done by using vice-grips to bend pan up full depth of sheet.

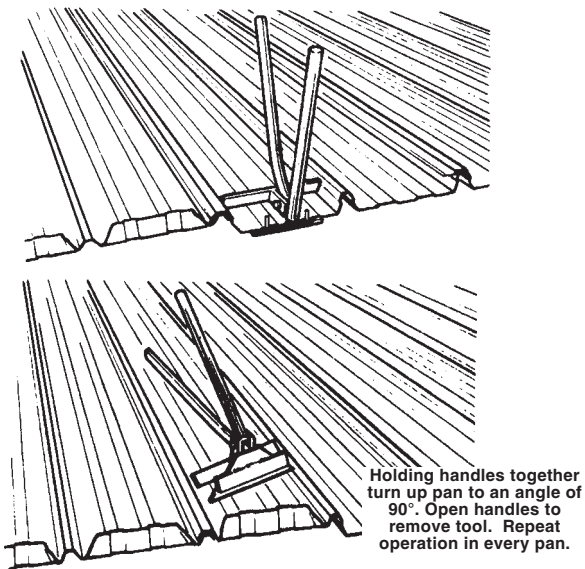

Brownbuilt Stop-Ending Procedure

Flush stop-ends are generally used with Brownbuilt® roofing, a tool is supplied for this

purpose. Stop-ending is usually carried out on the ground before installing the sheets on the roof structure.

Prior to the folding of the pan of the sheet, it is essential to remove the overlap portion of the female rib for at least 50 mm in length. For a flush stop-end the crown of the centre rib must also be cut for 50 mm from the end to enable the formed ears to be folded flush against the turned up tray. This is done with a rubber mallet while holding the stop-ending tool behind the turned up pan.

When using the Brownbuilt® stop-ending tool it is important that the tool is pushed home over the ends of sheets before the tool is raised through an Arc of 90°.

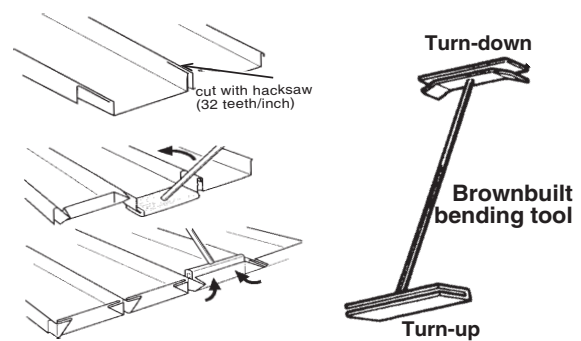

NOTE:

For Brownbuilt, an extra 50 mm should be allowed on the sheet length for flush stop-ending.

Stop ending at a rake

A stop end needs to be formed at a hip. This is best done by using vice grips with jaws to bend the pan up to the depth of the profile.

Where the sheets are rake cut at valley gutters, lipping should be effected over the full width of the pan.

4.5 Lipping

Regardless of roof slope, all concealed fix profiles roofing pans must be turned down through an arc of 20° at the low end of the sheet.

This lipping ensures that rainwater drains off the end of the sheeting and does not run back up the underside of the flat pans by capillary or wind action.

The mouth of the appropriate lipping tool (Klip-Lok®, Klip-Tite® or Brownbuilt®) is positioned over the end of the pan and push on as far as it will go. The tool is held hard against the end of the pan while the handle is swung through an arc of about 20° to form a lip on the end of the sheet.

The lipping operation is usually carried out after the sheeting is fastened on the roof before Brownbuilt gutters are fixed.

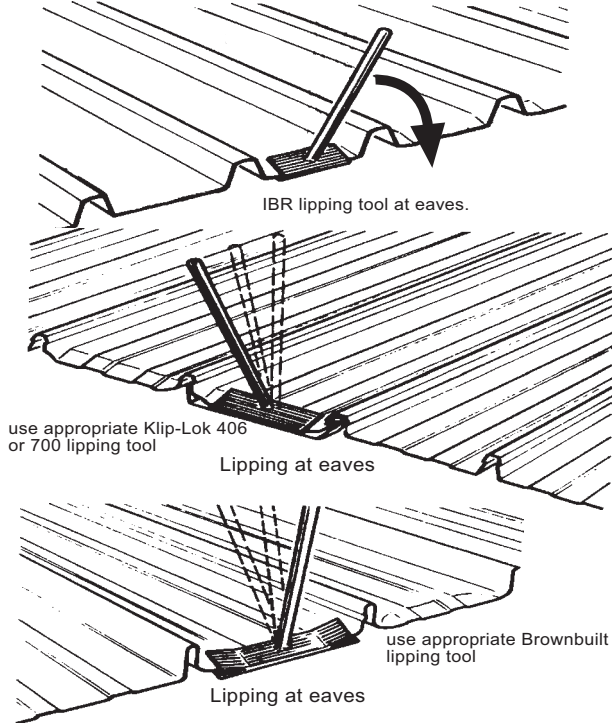

4.6 End Lapping

IBR, Nu-Rib & Corrugated

Statistics show that the most corrosion takes place at the endlap and that it should be avoided wherever possible.

Should it be necessary for transport or other reasons to end-lap pierced-fix sheeting, the following procedure should be adopted.

Lay each run of sheets in turn from bottom to top before moving onto the next run.

Numbers show sheet laying sequence

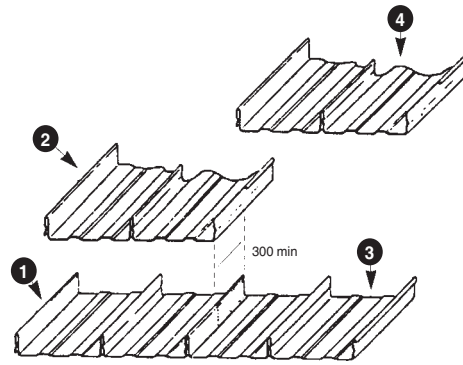
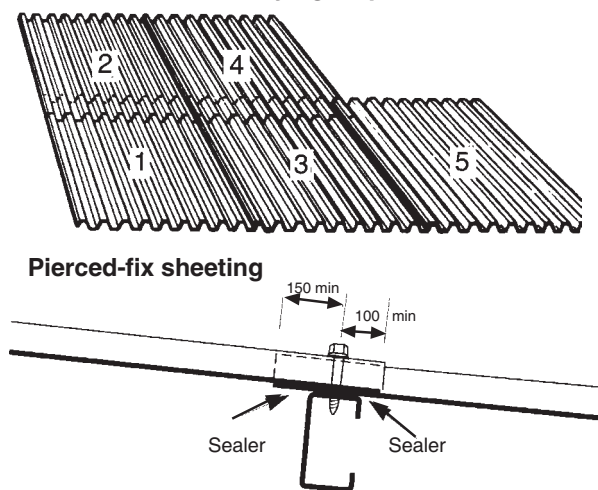

Brownbuilt (end laps are not recommended)

Sheets can also be rolled and cranked on site in lengths that make it unnecessary to end-lap. End lapping negates the concealed fixed concept and **no water tightness guarantee can be given**. However, the following procedure should be adopted should end-laps be required.

The first sheet is fixed in the normal manner. Before fixing second sheet the down-turn on the male rib of the sheet should be cut off for a distance of 300 mm. Fix both sheets to purlin with D2 duplex clip. The turn-down of the female rib of the third sheet must be cut off for a distance of 300 mm before fixing as per sheet one. Sheet four is cut and fixed as sheet two. All subsequent sheets are fixed as shown here.

All end-laps should be sealed with two runs of a recommended sealant.

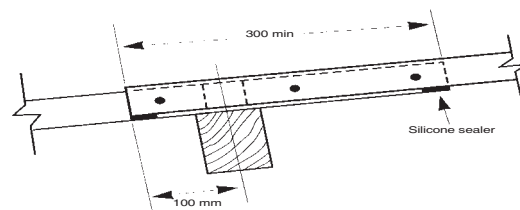

4.7 Recommended Step-lap/Expansion Detail

The clip fixing systems for Brownbuilt®, Klip-Lok® and Klip-Tite® allow for expansion and contraction, making it possible to utilise lengths restricted only by handling.

Should an expansion joint be required in the structure the sheets should be treated in the following manner.

An expansion joint can be provided at an end lap by raising all the purlins or supports for the roof sheeting on the high side of the lap to form a step 20 mm higher than the depth of the sheeting. The roof sheeting then overlap a minimum of 200 mm at the step and appropriate weatherproofing is provided. An extra purlin or support will be required at the step.

Transverse expansion joints are not necessary for the thermal movement in ribbed sheeting as each rib profile allows some transverse movement. The coefficients of expansion for various materials are given in Table 4.7 on the next page.

Note: For Klip-Lok® & Klip-Tite® form spur with pliers at end of eaves on upper sheet.

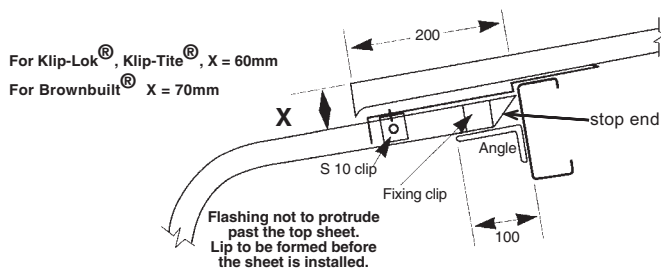
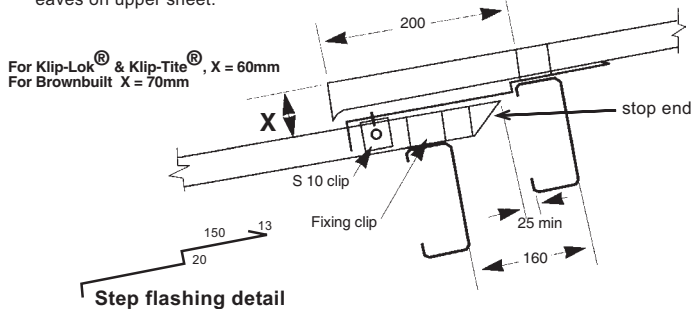

4.8 Expansion

An appreciation of the amount of expansion that occurs in metal roofs may be gained from the arbitrary example. A 15 m steel sheet expands 12 mm for a temperature variation of 65°C.

The actual expansion movement between the end of a sheet and the last support would be less than the figures shown because the movement in a length of fastened sheeting would normally take place from the centre towards each end of the sheet. The movement of each end is then only one half the expansion or contraction.

Table 4.8 Coefficient of Expansion

Material	Per °C	Expansion/m on 65° Temp. Change
Hot Dip Galv. Steel	12x10 ⁻⁶	0,78 mm
Stainless Steel	18x10 ⁻⁶	1,17 mm
Aluminium	23x10 ⁻⁶	1,50 mm
Copper	17x10 ⁻⁶	1,11 mm
GRP (Fibreglass)	25x10 ⁻⁶	1,63 mm
Polycarbonate Resin	70x10 ⁻⁶	4,36 mm

5. Flashing

Method of flashing for the range of GRS roof and wall sheeting are similar and the following details, with appropriate variations, would apply to all profiles. Flashings are available in Galvanised, pre-painted steel, 55% Aluminium Zinc Alloy coated steel, Aluminium or Copper. Flashing dimensions should be generous with ample cover width over roof sheeting and ample turn-up behind counter flashings. End lapping to be a minimum of 150 mm. For concealed-fix sheeting, no direct perforations should be made for fixings.

5.1 Longitudinal Flashings

Longitudinal flashings for Brownbuilt®, Klip-Lok® and Klip-Tite® should have a turn-down edge located into the pan of the roof sheeting and of a depth to suit the sheet profile. IBR and Corrugated flashings have standard bends along edges with closer pieces where required.

Brownbuilt®, Klip-Lok® & Klip-Tite® flashings should be fixed using S1 or S10 brackets to ensure that no holes are made directly through the sheet.

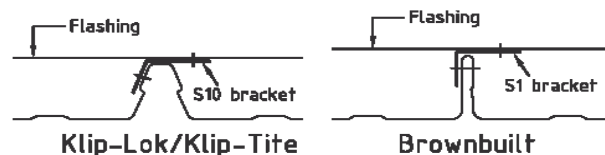

Sidewall Flashing

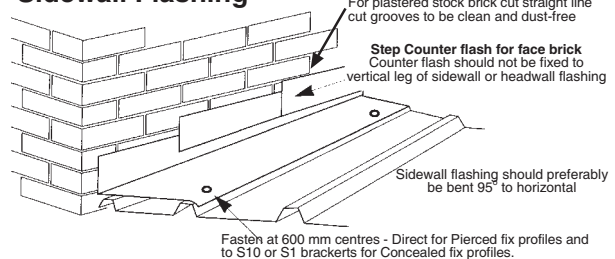

5.2 Transverse Flashing

Transverse flashings for Klip-Lok® & Klip-Tite® are usually notched out and turned along their lower edge to match the sheet profile. This provides a baffle against wind-borne moisture penetrating below the flashings. Notched flashings should be fixed with S1 or S10 brackets. No direct perforations are allowed for concealed fix sheeting.

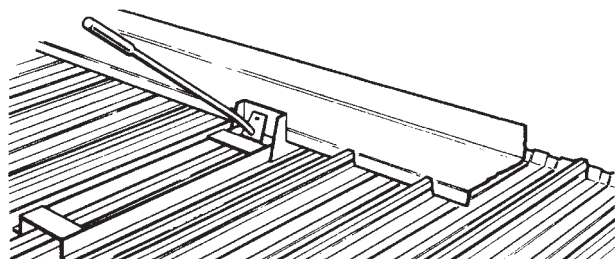

Headwall Flashing for Klip-Lok®/Klip-Tite®, notched & fixed to S10 clips.

Barge Flashing

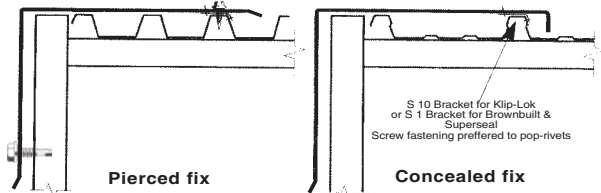

Notching tools are available to notch-out single rib profiles to match Klip-Lok®/Klip-Tite® and Brownbuilt®.

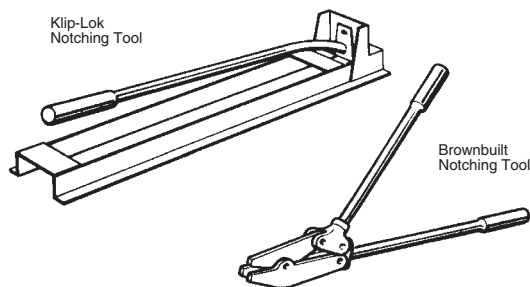

After the sheeting has been fastened and the pans turned up, the flashings are placed in position with the turned down edge on top of the ribs. Locate the notching tool over a sheet rib with the notching head against the turn down. Raise the handle to open the tool and lift the turned down edge of the flashing into the mouth of the tool. Push down on the handle to notch the rib profile out of the turn down in line with the rib. Raise the handle, lift the turned down edge sufficiently to relocate the tool on the next rib ready to notch, while retaining the flashings in its correct position. Repeat on each sheet rib along the full length of the flashing. Ensure clearance is maintained on both sides of each notch/cut-out to prevent scratching of the sheeting.

Alternatively two sheet-wide closers are available for Klip-Lok 406® or one sheet-wide closer for Klip-Lok 700®/Klip-Tite®.

Headwall Flashing for Klip-Lok/Klip-Tite (a similar principle would apply for Ridge & Apex flashings)

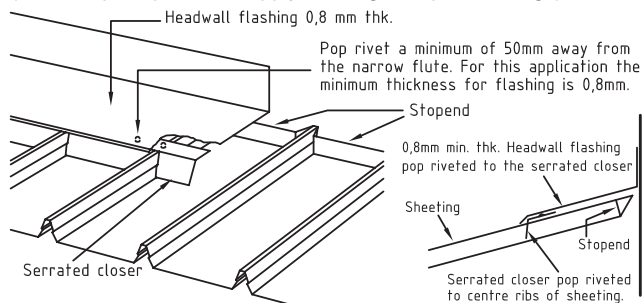

Transverse flashing for IBR sheeting have stiffening bends along the outer edges with pre-notched, one sheet width, closer pieces underneath to ensure weather proofing.

Headwall Flashing for IBR

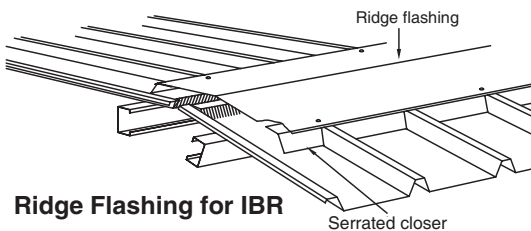
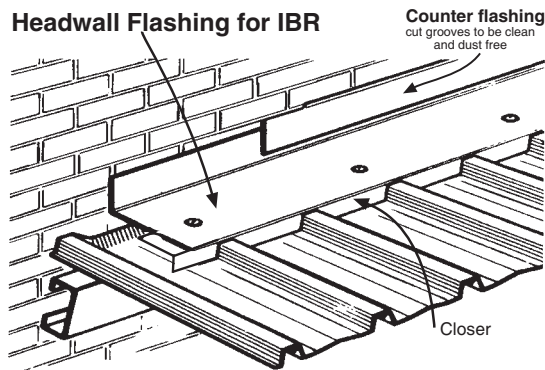

Transverse flashings for Corrugated usually have a stiffening bend along the lower edge. To ensure weather proofing this should be lightly dressed into the valleys.

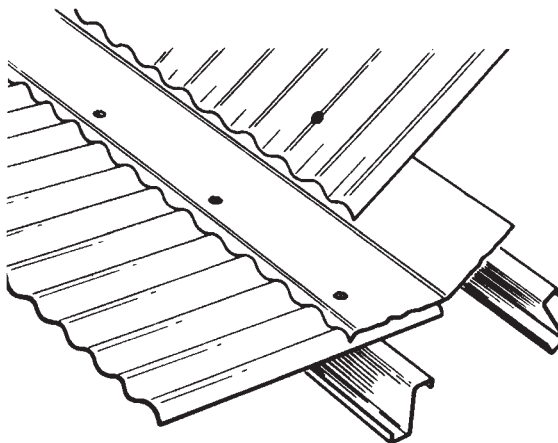

Change of Pitch Flashing (Apron flashing)

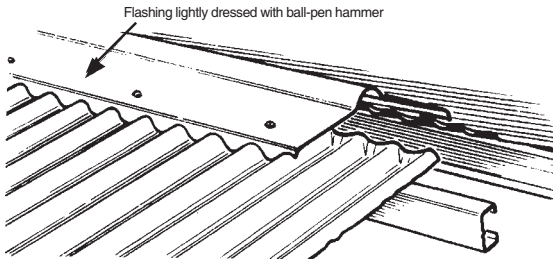

Sliding brackets are to be used for sheet lengths longer than 30 meters for Steel sheets and 20 meters for Aluminium sheets. Alternatively a 2-piece Expansion Ridge cap can be used.

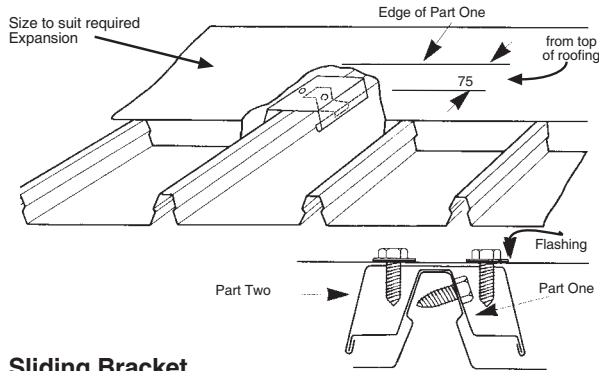

Sliding Bracket
Fix sliding brackets to centre ribs only, not on side lap.

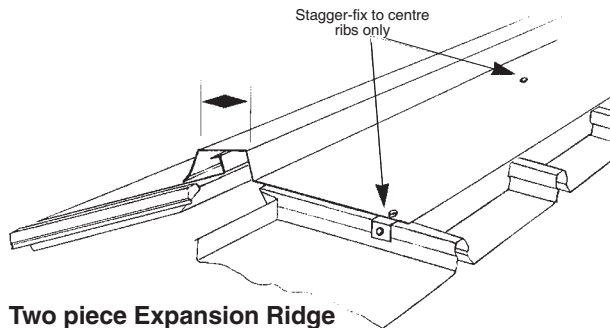

Two piece Expansion Ridge

Table 5.3 Fastener Frequency for Transverse Flashing

Profile	Fastener Frequency
Klip-Lok 406®	Centre Ribs
Klip-Lok 700®	All centre Ribs
Brownbuilt®	Centre Ribs
IBR & Nu-Rib	Alternate Flutes
Corrugated	Every fourth crest

5.3 Fastening Frequency for Transverse Flashings

Where possible, transverse flashings over IBR and Corrugated should be fastened in common with the sheeting with the normal sheet fasteners into the top purlin or support. Where the location of the top support does not permit pierce fastening with the

sheet fasteners, the flashing should be fastened to the ribs at the frequency shown in Table 5.1.

Transverse flashings for Brownbuilt and Klip-Lok are fixed in conjunction with S1 or S10 brackets at the frequency shown in Table 5.1. See table 4.2.2 & 4.2.3 for recommended fasteners.

5.4 Flashings around Roof Protrusions

On low pitched roofs, any protrusions through ribbed sheeting large enough to block one or more of the sheet drainage channels will require special attention to the flashing around the protrusion. This is to divert run-off from the blocked channels and can be achieved by fitting a head gutter across the high side. Run-off from the blocked channels is then discharged into clear channels either side of the protrusion.

The sheets on the high side of the protrusion to a width of a full number of sheets are lifted over three purlins to a height of the rib of the sheet plus 25 mm by placing Z section pieces of various depth on top of purlins. Taper flashings are then fixed to either side to close the gap. (This detail is only used on non-handed sheets like IBR and Nu-Rib)

If the distance from the back of the protrusion to the apex of the roof is less than 3,5 m then back flashing must be used.

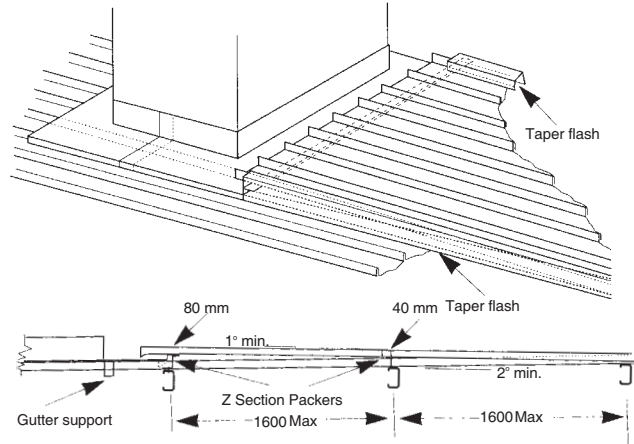

5.5 Pipe Penetration

Flashing around small pipe penetrations, which fit between the ribs of a roof sheet and allows free flow of water to ensure drainage or penetrate only single rib, is fairly simple. This requires a flanged cylindrical sleeve fastened and sealed to the roof sheeting around a clearance hole and the pipe penetration.

The sleeve is covered by a tapered skirt sealed and fastened to the pipe and there should be clearance between the skirt and sleeve and between the sleeve and pipe. This is to allow for thermal movement of the roof sheeting.

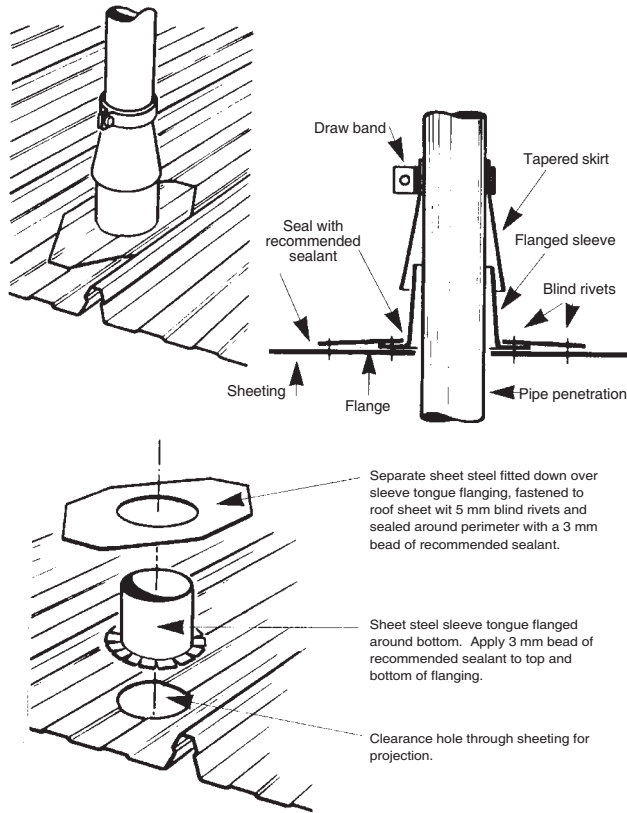

Where a pipe penetrates through the rib of a sheet is best flashed using flexible neoprene flanged sleeve which can be obtained for flashings around penetrations up to 300 mm diameter. The flange around the base of the sleeve can be contoured by hand to match the sheeting profile before it is sealed and fastened to the sheeting. This allows drainage of run-off down the trays or valleys each side of the penetration. The sleeve tapers up from the flange to a watertight fit around the penetration.

When using these neoprene sleeves care must be taken not to dam off any valleys or trays which would prevent water draining around them from the high side of the roof penetration. Moisture retention in such areas can cause deterioration of the sheet coating which may lead to a reduced life expectancy.

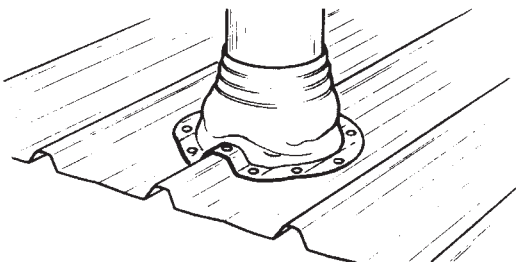

If the roof penetration can be located close to the apex of the roof, another alternative is to fit a simple flat cover flash on top of the sheeting extending from under the Ridge or Apex flashing down to a sleeve around the penetration.

Support Framing

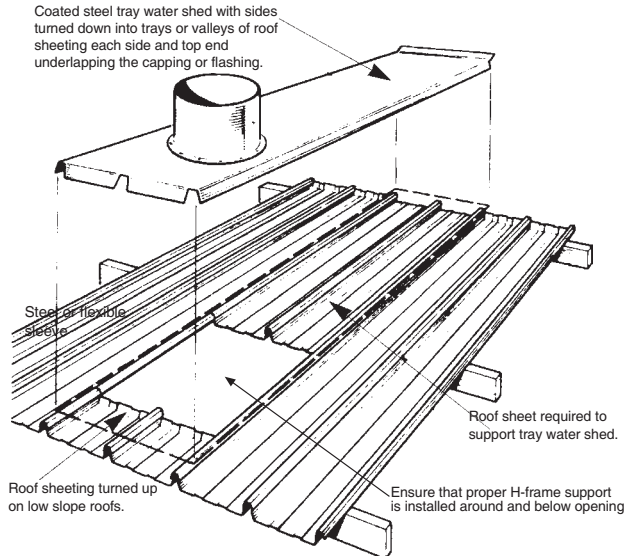

Wherever a roof penetration requires one or more of the sheet ribs to be cut, framing must be provided to support the cut ends of the roof sheeting each side of the penetration.

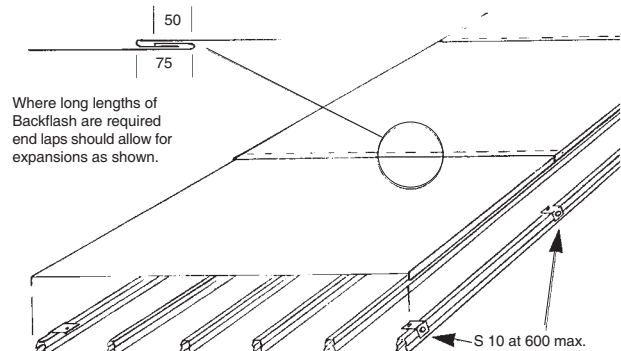
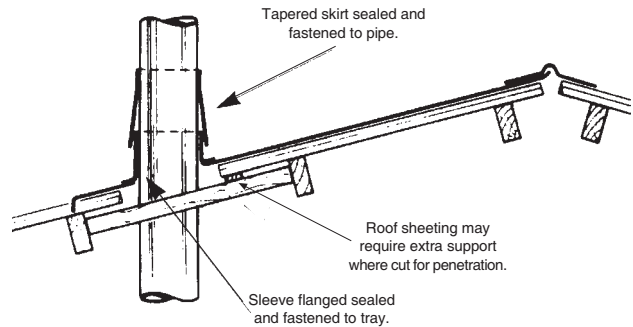

Back Flash

6. Rib Cap Bent Continuous Sheeting

On double-pitch roofs Klip-Lok and Brownbuilt can be used in continuous lengths from eave to eave by cutting the ribs and bending the pans at the ridge line. Bend must be done over a straight edge. Caps are then fitted and sealed over the cut ribs. This method provides a roof with very neat appearance with continuous pans and unbroken rib-lines over the ridge and down each side of the roof slope. However, fitting the rib-caps is time consuming and care must be taken with sealing to avoid any possibility of leakage. Care should be taken to ensure that the ribs of each sheet are cut at 90° to the longitudinal axis of the sheet. The ribs are easily cut with a metal cutting blade, in a power saw, set to the rib depth minus 2 mm. Any excess sealant must be removed the day after applying.

This detail is not recommended for a ridge detail with sheets longer than 30m either side. Sheets longer than 30m install sliding brackets. (20m for Aluminium)

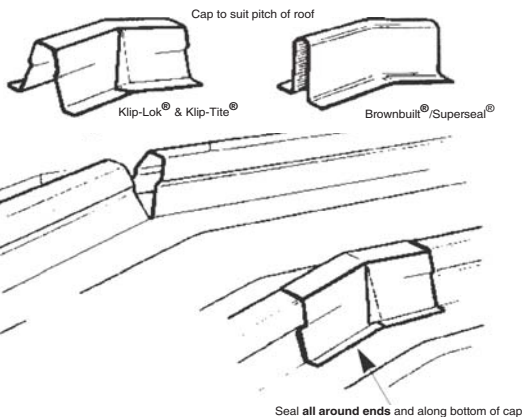
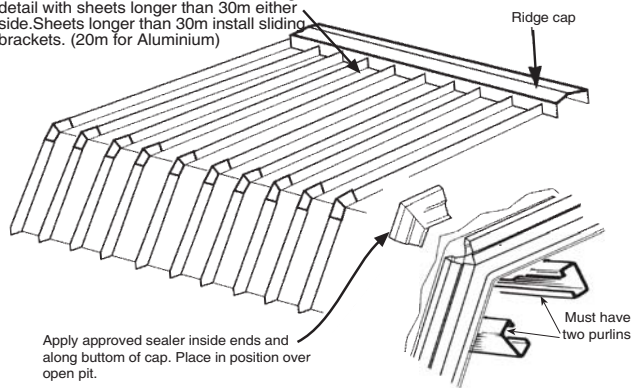

7. Cranking and Bullnosing Sheets

It is possible to crank or bullnose Klip-Lok®, Brownbuilt®, IBR and Corrugated to a minimum radius of 450 mm.

Bullnose or cranking is achieved by stamping in a series of indentations across the pan and up the side of the ribs at set distances, to give a "washboard" pattern to the sheet. The distance between the indentations determines the radius of the curve.

The cranking of sheets imparts greater rigidity and renders them less tolerant of misaligned supports. If cranked sheets are forced to follow badly aligned purlins or girts, sheet laps may not nest neatly, causing poor appearance or loss of waterproofing.

The steelwork therefore, has to be squarely aligned, be straight and true, with minimal deflection.

INSTALLATION PROCEDURES

Pierced Fix

For handling reasons IBR and Corrugated bullnosed sheets are often supplied in short lengths allowing for an end lap near the end of a roof. When this technique is employed, it is ABSOLUTELY ESSENTIAL that each run of bullnosed and straight sheets are end lapped progressively across the width of the roof so they can be kept in alignment. This applies to all profiles. See laying sequence below.

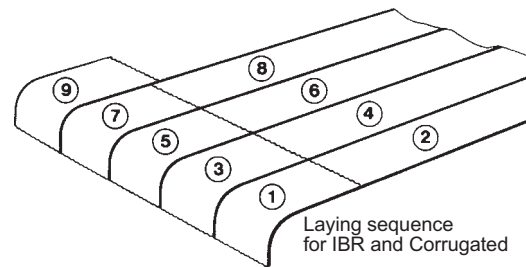

Concealed Fix

When bullnosed sheets are installed it is important that the indentations of adjacent sheets are aligned properly to ensure sidelap interlocking. This is best achieved by narrowing the male rib for the full arc length of the bullnose prior to installation.

8. Curved Sheeting

Curving of all GRS sheets, can be achieved by extending the distance between the indentations across the sheet – effectively increasing the radius. Brownbuilt®, Klip-Lok® & Klip-Tite® can be curved on site resulting in limitations governed only by handling. IBR & Corrugated has to be transported by road and is limited to a maximum cord height of 2 m and sheet length of 12 m.

9. Sprung Curved Sheeting

Convex

The Brownbuilt profile, the Klip-Lok & Klip-Tite® profiles, IBR and Corrugated can be sprung curved in single lengths over an arched roof, provided the radius of the arch is not less than the minimum listed for each sheet profile in the Table 9.1

Table 9.1- Convex

Profile	Min Rad.	Internal span (mm)
Brownbuilt ISQ 300 0,58 & 0,8mm	40 m	1,500
Klip-Lok 406 ISQ 550 (3T) 0.5 & 0.58mm	36 m	1,500
Klip-Lok 700 ISQ 550 (3T) 0.5 & 0.58mm	36 m	1,500
Klip-Tite ISQ 550 (3T) 0.5 & 0.58mm	55m	1,500
IBR 0.5 & 0.58mm	28.5 m	1,700
Corrugated 0.5 & 0.58mm	12 m	900

NOTE: Whenever sheets are sprung slight crease marks may appear in the pans. Increased radii reduces this effect. The same applies for a thicker sheet. In general, the narrower the sheet the less marks appear in the pan.

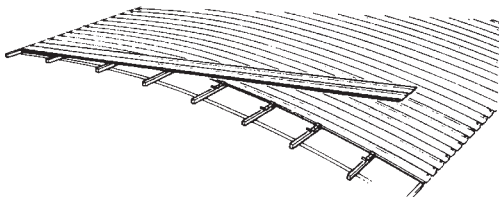

Where sheets are sprung curved, the cover width of the sheets tends to increase due to the curvature. For concealed fix this needs to be controlled by bending the male rib upright to ensure that the original cover width is not exceeded. This is done before the clip is located over the male rib.

Sealing top of the sheet

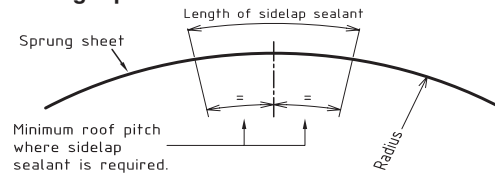

	Minimum roof pitch where sidelap sealant is required
Klip-Lok 406 & 700 & Klip-Tite	1°
Brownbuilt 406	1°
Superseal 500	1°
IBR 686 & 890	5°
Nu-Rib	7,5°
Corrugated	10°

$$\text{Length of sidelap sealant} = 0.035 \times \text{Radius} \times \text{Minimum Roof Pitch}$$

Concave

Brownbuilt®, Klip-Lok 406® (not KL700® & Klip-Tite®), IBR and Corrugated sheets can also be sprung to a minimum radii shown in Table 9.2 for concave roof applications.

Table 9.2 - Concave

Profile	Min Rad.	End Span	Internal spans(mm)
Brownbuilt	40m	Contact GRS offices	1,300
Klip-Lok 406	40m		1,500
IBR	28,5m		1,500
Corrugated 0.5 & 0.58	12 m		900

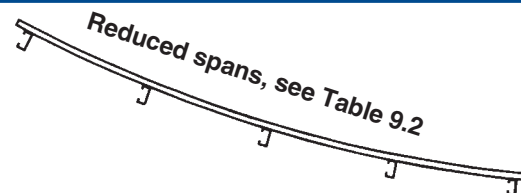

10. Translucent Sheeting

Two translucent materials are available for GRS sheeting. Glass Reinforced Plastic – (GRP/Fibreglass) or, Polycarbonate Resin. For availability refer Table 10.1 Regardless of reduced purlin spacings, avoid foot traffic on translucent sheets.

If single-width translucent sheets are used, supported both sides by steel sheets, purlin spacing need not be adjusted. More than one translucent sheet adjacent to one another, requires substantially reduced purlin spacings see Table 10.1. Polycarbonate is available in single width sheets except Klip-Lok 406 which is only available in a double width of 812mm (2 x Cover width of 406mm). GRS offers Polycarbonate colours in Clear or Opal as a standard.

Table 10.1 Translucent sheet availability

	GRP (1,8kg/m ²)	Polycarbonate (1,25mm)
Klip-Lok 406	✓	✓
Klip-Lok 700	✓	✓
Brownbuilt 406	☐	☐
IBR 686 & 890	✓	✓
Nu-Rib	✓	✓
Corrugated	✓	✓
Purlin Spacing(max.)		
-Roof	900mm	1300mm
-Side Cladding	1500mm	1500mm
Max. translucent sheet 9m		

NB: All holes in polycarbonate to be 10mm diameter.

It is preferable to position the lengths of translucent sheeting at the top of a roof run so that the top end is under the headwall or ridge flashing and the low

end overlaps the steel sheet. Due to translucent sheeting being thicker than steel, it will readily overlap the steel sheet but the reverse is difficult. This is especially the case with Klip-Lok sheeting. Because of its greater thermal expansion, translucent sheeting for pierce-fix (IBR) should be fixed using oversized holes and washers as recommended by the translucent sheeting manufacturer. With conceal-fix sheeting, care should be taken not to perforate the steel sheeting. Refer to drawing below for Klip-Lok translucent fixing detail. There are various methods of fixing translucent sheets in tandem with conceal-fix sheeting. All these methods are in conflict with the "concealed-fix concept" as the nature of the material requires it be pierced. It would therefore be excluded from any guarantees.

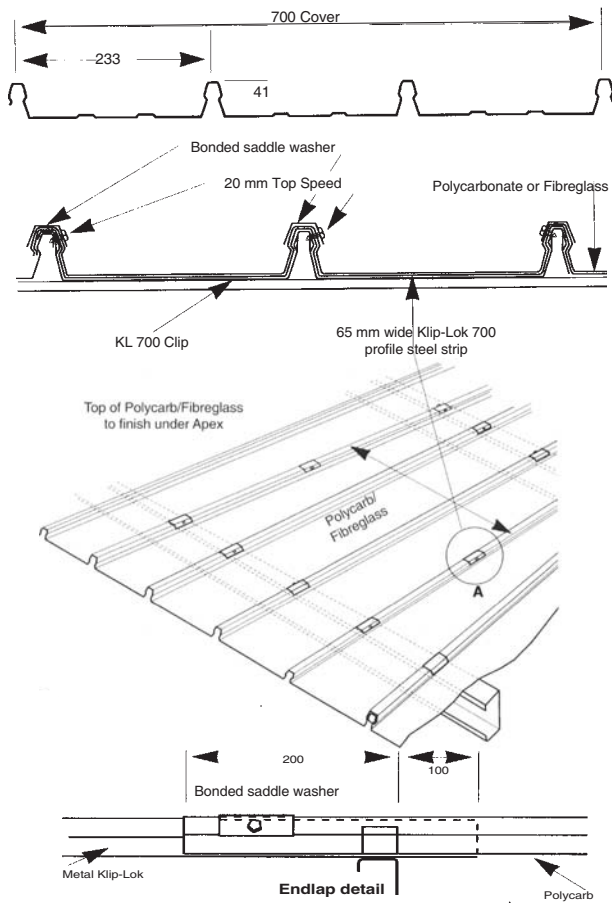
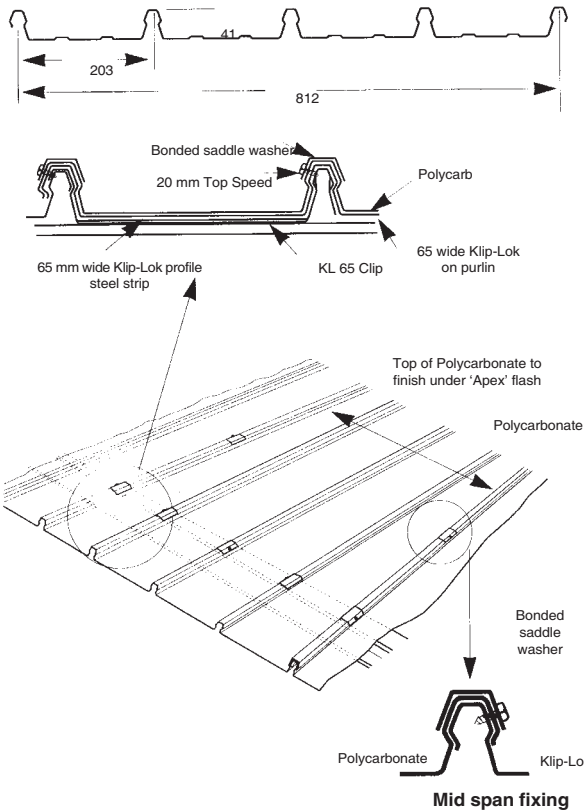

**Klip-Lok 406 Polycarbonate assembly (double sheet width)
The concept is similar for Klip-Lok 700.**

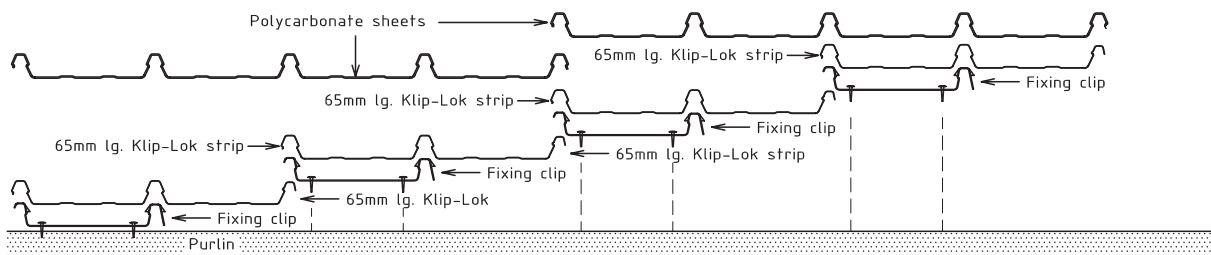

PROVISIONAL INFORMATION ON REQUIREMENTS FOR INSULATION BLANKETS - 1 Apr'14

ROOFING PROFILE		KLIP-TITE				KLIP-LOK 700			
Ultimate Wind Uplift Load		1,8 kN/m ²				1,6 kN/m ²			
Sheet Thickness		0,5mm	0,58mm	0,47mm	0,53mm	0,5mm	0,58mm	0,47mm	0,53mm
No Insulation	Max. Internal Span	2000 mm	2500 mm	1900 mm	2300 mm	2000 mm	2500 mm	1900 mm	2300 mm
	Max. End Span	1700 mm	2100 mm	1600 mm	1900 mm	1700 mm	2100 mm	1600 mm	1900 mm
	Max. Cantilever	180 mm	260 mm	150 mm	180 mm	180 mm	260 mm	150 mm	180 mm

TABLE B

ROOFING PROFILE		KLIP-TITE				KLIP-LOK 700			
Ultimate Wind Uplift Load		1,6 kN/m ²				1,6 kN/m ²			
Sheet Thickness		0,5mm	0,58mm	0,47mm	0,53mm	0,5mm	0,58mm	0,47mm	0,53mm
50mm thick Insulation Foil faced F/Glass (12kg/m ³)	Max. Internal Span	2000 mm	2500 mm	1900 mm	2300 mm	2000 mm	2500 mm	1900 mm	2300 mm
	Max. End Span	1700 mm	2100 mm	1600 mm	1900 mm	1700 mm	2100 mm	1600 mm	1900 mm
	Max. Cantilever	180 mm	260 mm	150 mm	180 mm	180 mm	260 mm	150 mm	180 mm
	Additional requirement	None	None	None	None	None	None	None	None
75mm thick Insulation Foil faced F/Glass (12kg/m ³)	Max. Internal Span	2000 mm	2500 mm	1900 mm	2300 mm	2000 mm	2500 mm	1900 mm	2300 mm
	Max. End Span	1700 mm	2100 mm	1600 mm	1900 mm	1700 mm	2100 mm	1600 mm	1900 mm
	Max. Cantilever	180 mm	260 mm	150 mm	180 mm	180 mm	260 mm	150 mm	180 mm
	Additional requirement	6 Screw fixing	6 Screw fixing	6 Screw fixing	6 Screw fixing	20x75mm packer	20x75mm packer	20x75mm packer	20x75mm packer
100mm thick Insulation Foil faced F/Glass (12kg/m ³)	Max. Internal Span	2000 mm	2500 mm	1900 mm	2300 mm	2000 mm	2500 mm	1900 mm	2300 mm
	Max. End Span	1700 mm	2100 mm	1600 mm	1900 mm	1700 mm	2100 mm	1600 mm	1900 mm
	Max. Cantilever	180 mm	260 mm	150 mm	180 mm	180 mm	260 mm	150 mm	180 mm
	Additional requirement	6 Screw fixing	6 Screw fixing	6 Screw fixing	6 Screw fixing	20x75mm packer	20x75mm packer	20x75mm packer	20x75mm packer
115mm thick Insulation Foil faced F/Glass (12kg/m ³)	Max. Internal Span	1800 mm	2300 mm	1700 mm	2100 mm	2000 mm	2500 mm	1900 mm	2300 mm
	Max. End Span	1500 mm	1900 mm	1400 mm	1700 mm	1700 mm	2100 mm	1600 mm	1900 mm
	Max. Cantilever	150 mm	220 mm	130 mm	150 mm	180 mm	260 mm	150 mm	180 mm
	Additional requirement	6 Screw fixing	6 Screw fixing	6 Screw fixing	6 Screw fixing	30x75mm packer	30x75mm packer	30x75mm packer	30x75mm packer
135mm thick Insulation Foil faced F/Glass (12kg/m ³)	Max. Internal Span	1600 mm	2100 mm	1500 mm	1900 mm	2000 mm	2500 mm	1900 mm	2300 mm
	Max. End Span	1300 mm	1700 mm	1200 mm	1500 mm	1700 mm	2100 mm	1600 mm	1900 mm
	Max. Cantilever	130 mm	190 mm	110 mm	130mm	180 mm	260 mm	150 mm	180 mm
	Additional requirement	6 Screw fixing	6 Screw fixing	6 Screw fixing	6 Screw fixing	40x75mm packer	40x75mm packer	40x75mm packer	40x75mm packer

Note !

- As indicated in Table A, if no insulation blanket is used at the standard maximum purlin spacings, Klip-Tite has a greater wind-uplift resistance than Klip-Lok 700.
- Table B may be used as a guide to establish the additional requirement when Fibre Glass insulation blankets are used over purlin. If the spans given above are exceeded, please contact GRS.
- Where "6 screw fixing" is applicable, refer to Drawing showing the fixing method to be complied with.
- All packers are to be 75mm wide in the various thicknesses as shown above.
- Ensure fasteners are of the correct specification and length to allow at least 3 threads to protrude below the steel purlin .
- The above table do not apply where insulation densities above that shown is used.
- The above table do not apply when light steel frame purlins are used. Contact GRS

6 Screw Fixing

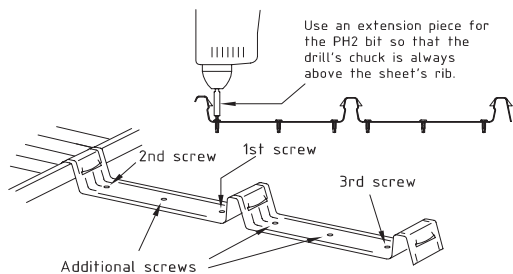

Packer Detail

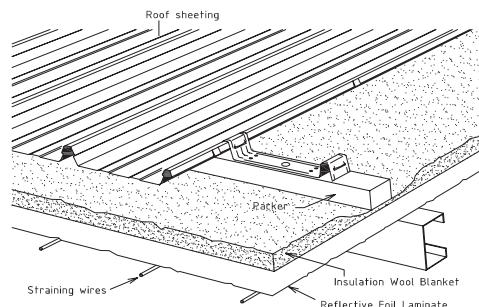

11. Insulation

To reduce the transmission of heat from solar radiation into a building, insulation can easily be incorporated in the roof system during installation of the roof sheeting. For Concealed fix sheeting, fixing clips need to be stabilised depending on the type of insulation used.

There are basically three types of insulation, these being:

1. Reflective Foil Laminate/Bubble Foil

Foil laminate as an insulation acts to reduce the transmission of heat from solar radiation into a building by reflection. To be able to insulate effectively, it is necessary to allow an air space between the top face of the laminate and the under side of the roof sheet.

The foil laminate is easily incorporated into the roof system during the installation of the roof sheeting by firstly installing straining wires over the top of the purlins from apex to eave. The foil laminate is then laid over the straining wires from apex to eave and temporarily fixed to top and bottom purlins. Permanent fixing is achieved with fixing of roof sheets.

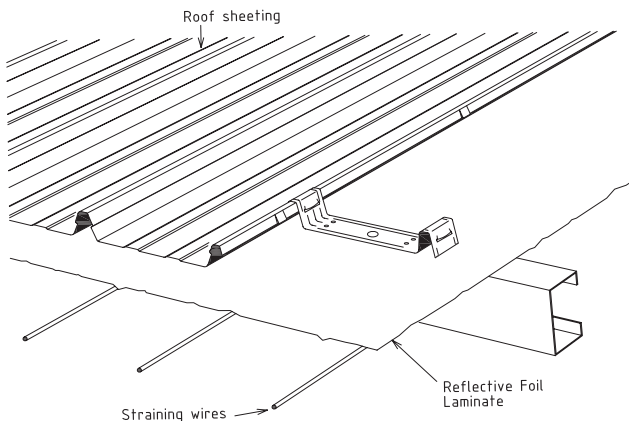

2. Fibreglass/Laminated Foil or Mineral-wool

Resin bonded fibreglass wool with a laminate of either Kraft Aluminium Foil (or colour coated foil) of various thicknesses is a high quality insulation material that can be easily fixed in a similar manner to the reflective foil laminate as described in 1. above. For concealed fix sheeting, blankets thicker than 50mm may require additional measures to be taken, see table on p25

Note: For insulation material thicker than 50mm, the clips may need to be elevated with 'packers' to facilitate the sheets to clip in, and to prevent the rocking of clips.

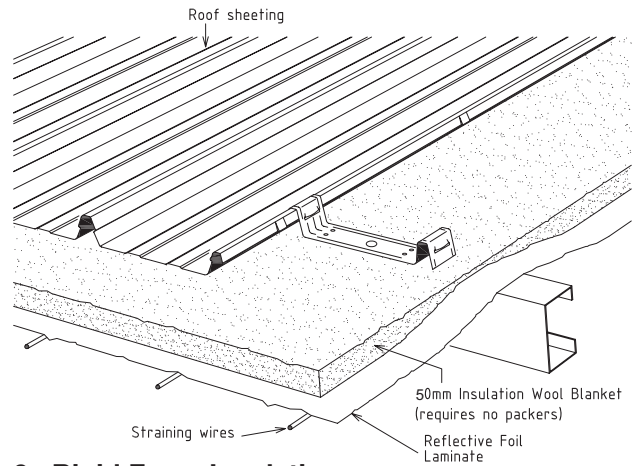

3. Rigid Foam Insulation

Rigid foam panel sandwiched between surfaces of aluminium foil, mill finish or white laquered. Installation is normally over purlins together with the roof sheeting.

Insulation boards are placed over purlins with ends butt-jointed over purlins. For pierced fixed sheets, the sheets are placed on top of boards and fixed through sheet and board into purlins with fixing screws of adequate length to penetrate sheet and board.

For Lambdaboard (polyisocyanurate), stabilise clips by pressing u-spacers into the board directly under the fasteners (see sketch)

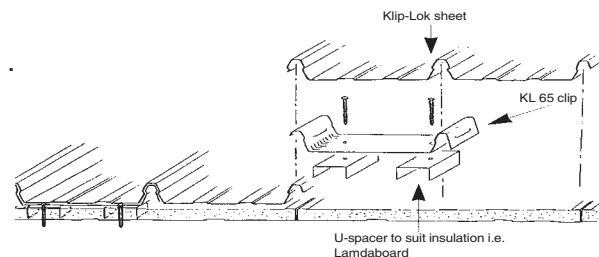

For Iso board (styrene) place a 150mmx0.8mm galv steel strip over the board the entire length of the purlin. The fixing clips are placed on top of the strip (see sketch). Screws of sufficient length are fixed through into the purlin.

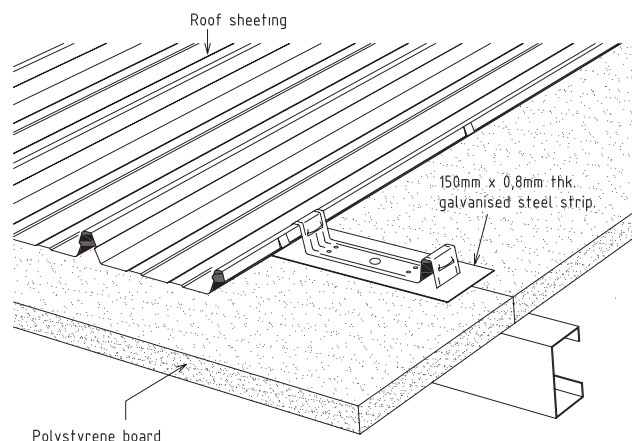

12. Rainwater Run-off

The rainwater of run-off capacity of roof sheeting is a limitation on the total length of a sheet run that must be considered in roof design and construction.

As a guide, Table 12.1 lists the maximum recommended length of roof run for various G.R.S. sheet profiles at the roof slopes and rainfall intensities shown.

The roof run is the total length of roof sheeting draining rainwater in one direction including any endlaps, expansion joints or steps that may be presented in the roof.

13. Gutter Capacity

The gutter cross-sectional area given in Table 13.1 are provided for guidance only. Where more design detail is required, the South African Steel Construction Handbook Section II should be consulted

Table 12.1 Maximum Roof Run (in metres) for Roof Slopes & Rainfall Intensities (providing the free flow of water is not restricted)

Sheet Profile	Rainfall Intensity mm/hr	Roof Slope					
		1:50	1:30	1:20	1:12	1:7.5	1:6.0
Klip-Lok® & Klip-Tite®	250	64	80	94			
	300	53	66	78	95		
	400	40	50	58	70	83	91
	500	32	40	46	56	66	73
Brownbuilt	250	100					
	300	85	100				
	400	63	80	94			
	500	51	64	75	90	100	

Table 13.1 lists a selection of roof catchment areas that are drained by one downpipe and shows the cross sectional area of gutter required for a range of rainfall intensities. The roof catchment area for each downpipe is the length of the roof run (ridge to gutter), multiplied by the spacing between downpipes.

Table 13.2 is an extract from the South African Steel Construction Handbook and shows rainfall intensities for selected localities, related to 5 minutes duration storms and a return interval of 50 years.

It is suggested that for design purposes the following five minute duration rainfall intensities be adopted for gutter and downpipe design, assuming a 20 year return storm.

Summer rainfall region	200mm/hr
Year-round rainfall region	150mm/hr
Winter rainfall region	100mm/hr

TABLE 13.1 GUTTER SIZES FOR VARIOUS RAINFALL INTENSITIES AND ROOF CATCHMENT AREAS PER DOWNPIPE

Roof Catchment Area	10 m ²	20 m ²	50 m ²	100 m ²	200 m ²
Rainfall Intensity (mm/hr)	Cross sectional area of gutter required to drain above roof catchment area into one downpipe mm ²				
80	1300	2200	4600	800	1400
90	1420	2400	5100	8750	15220
100	1540	2600	5500	9450	16430
120	1630	2800	5890	10150	17630
130	1850	3180	6670	11530	20000
140	1950	3370	7050	12210	21170
150	2050	3560	7430	12890	22330
160	2150	3750	7810	13570	23490
175	2300	4030	8370	14570	25210
200	2550	4480	9290	16220	28060
225	2800	4920	10200	17820	30860
275	3300	5760	12000	20920	36400
325	3780	6560	13750	23920	41700
425	4650	8060	16800	29250	51000

Note: For internal box gutters add 25 mm of Freeboard depth to cross sectional areas given in Table 12.1. Water draining from parapet walls must be allowed for.

Eaves gutters should have a fall towards the outlets 1 in 500 and internal box gutters a fall of 1 in 200. If for some design or other consideration, gutters are installed without a fall, ponding will result and this could reduce the life of the gutter. In such situations the gutter should be cleaned out regularly.

With high fronted eaves fascia gutters, care should be taken to prevent overflow from the back of the gutter into the building, in the event of a blocked downpipe. This can be done by providing drainage slots along the front of the gutter. Alternatively the outer vertical leg can be lower to create an overflow.

14. Downpipe Capacity

The cross-section of a downpipe from an eaves gutter should be 65mm² for each square metre of roof area draining into the downpipe.

The cross-section of a downpipe from an internal box gutter should be 100 mm² for each square metre of roof area draining into the downpipe.

**TABLE 13.2 DESIGN RAINFALL INTENSITIES
- 5 MINUTES DURATION**

Rainfall Region	Location	50 Year Recurrence Interval Five Minute Rainfall Intensity mm/hr
Summer	Johannesburg	301
	Nelspruit	291
	Escourt	258
	Newcastle	323
	Bloemfontein	261
	Durban	340
	Polokwane	250
Year-round	Port Elizabeth	241
Winter	Cape Town	142

However, the minimum cross-section of any downpipe should be at least half that of the gutter from which it drains.

It is good practice to provide drainage sumps at downpipe connections to gutters or at least have funnels at the head of each downpipe, particularly for internal box gutters.

Where possible downpipes should be spaced at no more than 18 m centres

15. Hail Guards

Hail guards are generally installed as:

1. Hail protection
2. Protection against leaf build-up and wind blown garbage.
3. Outlet protection.

Although hail guards will not provide for every eventuality, good design can help to prevent restricting free-flow of water. This is especially true for gutters concealed behind parapet walls. Hail guards should for instance never be installed under the overhang of roof-sheeting as hail build-up in this area could present problems with ingress of water into the building. It should rather attempt to retain the hail on top of the sheet. Where possible, consideration must be given to providing overflows (pipes through the wall) at a lower level than the inner vertical leg of the gutter. This will help where an outlet has become restricted.

Where eaves gutters are not concealed it is advisable to design the gutter with the outer vertical leg lower than the inner leg. This will allow a natural flow of water in case of hail or leaf build-up. If this cannot

be achieved, consideration should be given to the provision of overflows at a lower level than the inner vertical leg of the gutter as described above.

It may be useful to consult the SAISC Red Book under the heading "Drainage", which could provide some assistance in the design of hail guards.

16. Condensation

To minimise the risk of condensation under roof sheeting a vapour barrier should be provided on the underside to prevent contact with moist air.

The reflective foil laminate which provides heat insulation under the roof sheeting can serve a dual function as a vapour barrier simply by sealing the overlaps with a moisture impervious adhesive tape. The laps should be about 10 mm and kept in close contact when positioning the laminate so the tape can be readily applied.

The laminate must be allowed to drape between roof supports so the cold temperatures of the roof sheeting will not be transmitted to the laminate by contact. If this were to happen condensation could form on the underside of the laminate.

Condensation under roof sheeting occurs when the sheeting becomes colder than the air in contact with it and water vapour in the air condenses on the sheet. It is somewhat unpredictable and many types of buildings are subject to the problem. On a cool, clear night, roof sheeting will radiate heat into the atmosphere until the temperature of the sheeting drops below that of the surrounding air, sometimes by as much as 5°C. The sheeting can continue to radiate heat and remain colder than the air in contact until it is subjected to, and warmed by, radiation from the sun. During this time the water vapour in the air will continue to condense on the underside.

The amount of condensation will depend on the amount of water vapour in the air and this varies with climatic conditions. Activities within a building can add substantially to the amount of water vapour in the air. In a house this applies to bathing (particularly showering), cooking, washing machines, clothes dryers, dishwashers and even the presence of people. Moisture will pass fairly freely through most ceiling linings into the ceiling space where it may directly contact the roof sheeting.

In addition to the obvious problems of water dripping from the roof of ceiling and staining of the ceiling and walls, condensation can lead to deterioration of inaccessible building components. Also, if bulk insulation is wet or even slightly dampened by condensation its efficiency will be drastically reduced.

If condensation occurs in a building it is both difficult and costly to eradicate so it is wise to take precautionary measures during design and construction. To avoid condensation in a roof, moist air must be prevented from contacting the underside of the sheeting. The inclusion of insulation wool between the reflective foil laminate and roof sheeting, will further exclude the intrusion of moist air. It will also further insulate the laminate from the cold sheeting during condensation conditions.

17. Sealants

It is important that the correct sealant is used and the manner in which it is applied is correct as this is the means by which the roof is made waterproof.

There are a number of sealants on the market of which the most commonly used in the roofing industry are Silicone and Butyl. Both Silicone and Butyl are available in 300 ml cartridges. Butyl is also available in ribbon or strip form - 8 x 3 mm and 5 mm dia.

It must be noted that only Silicone sealants that are acetic acid free must be used on galvanised surfaces. This is due to the fact wet conditions during the early stages of sealant cure can promote a corrosive situation.

The above-mentioned sealants are suitable for use with galvanised, colour coated, aluminium, stainless steel, copper, polycarbonate and fibreglass.

It is important that when using any sealant that the surfaces to which it is to be applied must be clean and dry.

Please note that whilst all care has been taken to ensure the accuracy of data in this publication, no responsibility can be accepted by GRS for any errors or omissions.

18. ROOF FIXING - WHAT TO DO

How to ensure you maximise the life of your roof when installing Steel Roofing.
To maximise the life of your roof observe the following Do's and Don'ts.

WHAT TO DO

Care and storage: -

- Material should be stored dry at all times, therefore cover stack with a tarp and stack sheets or bundles clear of the ground to avoid material getting wet.
- Should material get wet, unpack wet sheets to allow drying. Use a clean cloth to remove surface moisture, and stack in such a way that air circulation completes the drying process.

Walking on Roof Sheeting: -

Clean soft-soled shoes should be worn. Dunlop-Volley shoes are recommended for use when installing and inspecting roof sheets.

- Keep weight evenly distributed over the soles of the feet, as new sheets may be slippery.
- Walk on purlin lines wherever possible.

Compatibility: -

- Always use coated steel purlins and girts to avoid any ZINCALUME® steel or pre-painted steel contact with bare steel or treated timber.

Bending: -

Bending of pre-painted steel should preferably be done without the use of a lubricant.

Cutting sheets on site: -

- use metal blades rather than carborundum discs/angle grinders as they produce fewer damaging hot metal particles, leaving fewer burrs on the cut sheet. GRS recommends the use of cold cutting saws such as the Makita 4130 unit or an equivalent saw with appropriate blade.

Fasteners and accessories: -

- All screws should have rubber sealing washers. Rubber washers should be EPDM quality or the equivalent and be free of carbon fillers.
- Buy fasteners that are as durable as the roof sheeting you have purchased and that comply with class AS.3566 Class 3. (AS3566 is a performance based standard that specifies a minimum coating thickness for fasteners to be used in benign (Class 1) to severe marine (Class 4) environments.)

Use of sealants: -

- Use neutral cure silicone rubber sealants which offer the following:
 - a) Good adhesion to the clean surface of roof sheeting.
 - b) Water resistance and non-corrosive to the sheeting.
 - c) Resistance to extremes of heat and cold while retaining good flexibility.
 - d) Provide high resistance to ultra-violet rays (sunlight) and have a long service life.
- Mineral turpentine is suitable for cleaning **only** the surfaces to be adhered and remove all residual solvent with a dry cloth. While spirits such as Shell X-55 can also be used to clean the surfaces to be sealed.

Swarf removal: -

- Remove all metal scraps, pop rivet mandrels and excess fasteners from the roof at least daily to avoid rust stains.
- When cleaning up after having installed roof sheets clean out the gutters, ensuring not to leave metal tailings.

Brick cleaning: -

- Ensure that brickwork that sits above / adjacent to a section of roof is cleaned before roof and gutter installation.

Following Trades: -

- Pipes and other penetrations made from copper or lead must be post painted to prevent the deposition of metallic copper ions upon the roof surface. Failure to comply with this requirement will result in the accelerated corrosion of the roof sheet.
- Any mortar/concrete should be removed immediately from the roof sheets.

Detergents & Cleaners: -

- Only non-ionic detergent or "kitchen" detergent are recommended for cleaning of roof sheets. (A soft cloth, mop or soft nylon bristle brush may be used.)

19. ROOF FIXING - WHAT NOT TO DO

How to ensure you maximise the life of your roof when installing Steel Roofing.
To maximise the life of your roof observe the following Do's and Don'ts.

WHAT NOT TO DO

Care and storage: -

- Store packs of sheets in the open.

Cutting sheets on site: -

- Cutting should not be carried out on top of other roof sheets.

Roof Fixing Battens: -

- Do not use copper/chrome/arsenic (CCA) treated timber battens/purlins as perforation of the roof sheet can occur. Separate CCA treated battens from roofing sheets with appropriate barrier such as insulation paper.

Compatibility: -

- Lead and copper are not compatible with pre-painted steel or ZINCALUME[®] steel products.

Bending: -

- Do not use kerosene or distillate on pre-painted steel as they soften the paint film.

Use of sealants: -

- Do not use acetic acid based sealants. While being ideal for use with other materials they liberate aggressive by-products during curing which is detrimental to sheet steel. These often have a vinegar or ammonia smell.

Swarf removal: -

- Do not leave metal articles on the roof.

Brick cleaning: -

- Do not allow brick cleaning fluids to spray onto or flow across sheeting and into gutters. This can lead to premature failure of the paint and corrosion of the metal.

Fasteners and accessories: -

- Do not use galvanised steel ridge cap flashing or gutters with a ZINCALUME[®] steel or pre-painted steel roof. The galvanised steel will need to be replaced at an earlier interval.
- Do not use stainless steel screws, galvanised washers, cadmium plated screws or other type of screw that doesn't comply with AS 3356 Class three with ZINCALUME[®] steel or pre-painted steel as this will lead to premature failure of the roof sheet.

Surface damage: -

- Touch up paint is not recommended to repair surface scratches on pre-painted steel. The different weathering pattern of touch up paint will lead to an inconsistent colour across the sheet's surface. It is recommended that severely damaged sheets be replaced.
- If the pre-painted steel sheet is only scratched back to the steel coating, leave the scratch bare as the sacrificial properties of Zinc will protect the surface from corrosion.
- If the sheet is scratched back to the cold rolled metal base and the scratch is greater than 2mm wide, sacrificial protection will be reduced and those sheets should be replaced.

Following Trades: -

Do not mount roof air conditioning units on CCA treated timber. Also do not place CCA treated timber or green hardwood dunnage on roof sheets.

Detergents & Cleaners: -

- Never use abrasive or solvent type cleaners (turpentine, petrol, kerosene, paint thinners) on pre-painted steel / ZINCALUME[®] / galvanised steel surfaces.
- Never use wire brushes, steel wool, sponge scourers to clean the roof sheet.

PLEASE LEAVE
THIS FLAP INTACT

CUT ALONG
DOTTED LINE

IMPORTANT - WE WOULD LIKE TO HEAR FROM YOU!

In the Building and Construction Industry work is carried out in accordance with the appropriate Codes. Where Codes do not exist, established standard working practices are employed. The recommendations in this Manual are based on both principles.

However, we earnestly invite the users of this Manual to let us know if there is a procedure or practice that practical experience has shown to be an improvement. We may be able to use it in our next printing. Please cut out this part page and send it with your suggestions to:

**Global Roofing Solutions, - Technical Advisory Service
P.O. Box 6461, Dunswart 1708**

FROM:

NAME: _____

ADDRESS: _____

Reference Page No.: _____ or Item _____

Our comments:

If insufficient space please attach a plain sheet.

PLEASE CUT ALONG DOTTED LINE



A Blackstar PLC company

GRS Boksburg
Brownbuilt & HH Robertson
Tel: +27 (0) 11 898 2900

GRS Rustenburg
Roofzone
Tel: +27 (0) 14 596 6121

GRS Namibia
Country Roofing
Tel: +264 (0) 61 263 890

GRS Durban
Tel: +27 (0) 31 579 7555

GRS Bloemfontein
Tel: +27 (0) 51 432 3724/6

GRS Cape Town
Tel: +27 (0) 21 521 1900

GRS East London
Tel: +27 (0) 43 731 1895/98

GRS Zambia
Tel: +260 96 7495541

GRS Botswana
Tel: +267 310 5761

GRS Exports
Tel: +27 11 898 2900

Helm Engineering
Tel: +27 11 876 1300

www.globalroofs.co.za

